



**STRONG PARTNERS.  
TOUGH TRUCKS.™**



# **HYSTER UT SERIES**

## **SEATED ELECTRIC TOW TRACTOR**

**T3.OUT / 3000 KG**

**[HYSTER.COM.AU](http://HYSTER.COM.AU)**

# T3.OUT

**THE HYSTER® SEATED ELECTRIC TOW TRACTOR T3.OUT COMBINES ERGONOMIC FEATURES AND RELIABLE PERFORMANCE WITH ENERGY EFFICIENT TECHNOLOGY. LOW MAINTENANCE DELIVERS INCREASED PRODUCTIVITY AND REDUCED OPERATIONAL COSTS.**

## Productivity

- High-power maintenance free AC drive motor
- Impressive pulling performance
- Seamless travel and manoeuvrability
- Rear dual-position tow coupling
- Ergonomic layout to maximise operational efficiency and safety
- Adjustable seat and steering column
- Multi function LCD dash display
- Automatic electro-magnetic parking brake

## Serviceability

- Easy access for fast and efficient servicing
- Simple, readily available components
- Computer based diagnostics not required

## Safety & Structural Design

- Operator Presence System (OPS)
- Non-slip, uncluttered floor plate
- Drive axle design and low centre of gravity enables excellent stability
- Emergency stop button
- Audible reverse alarm
- High quality, robust components
- Low noise level

## Optional Features

- Battery side extraction
- Keyless key switch (password)
- Blue light and strobe light
- Rear view mirrors
- Paper document storage compartment



Easy Service Access via Back Cover



Ergonomic Operator Compartment



Informative LCD Dash Display

MODEL	MEASUREMENT	T3.OUT
Power Type		36-Volt
Operator Type		Seated
Rated Capacity	kg	3000
Drawbar Pull, 60min rating	N	750
Max Drawbar Pull, 5min rating	N	☞
Wheelbase	L1 (mm)	1055
Rear Load Distance	L2 (mm)	382
Service Weight	kg	780
Axle Loading, unladen front / rear	kg	310 / 470
Front, Tyre size / type (No. of Wheels)		15x4.5-8 Solid (1)
Rear, Tyre size / type (No. of Wheels)		15x4.5-8 Solid (2)
Wheel Tread, front	mm	n/a
Wheel Tread, rear	W1 (mm)	860
Seat Height / STD	h3 (mm)	910
Coupling Height	h1 / h2 (mm)	280 / 350
Overall Length	L (mm)	1720
Overall Width	W (mm)	968
Overall Height (excluding cab)	H (mm)	1270
Approach Angle	$\alpha 1$ (°)	$\geq 54$
Departure Angle	$\alpha 2$ (°)	$\geq 37$
Min Ground Clearance	X (mm)	90
Turning Radius	Wa (mm)	1490
Travel Speed, unladen	km/h	10
Travel Speed, laden	km/h	7
Gradeability, laden / unladen	%	7 / 12
Service Brake / Parking Brake		Hydraulic / Electromagnetic
Drive Control		AC
Drive Motor Rating *S2 60 min	kW	3
Battery Ampere Hours	Ah	250
Battery Weight	kg	202
Sound level at the drivers ear according to EN / DIN 12053	dB (A)	68

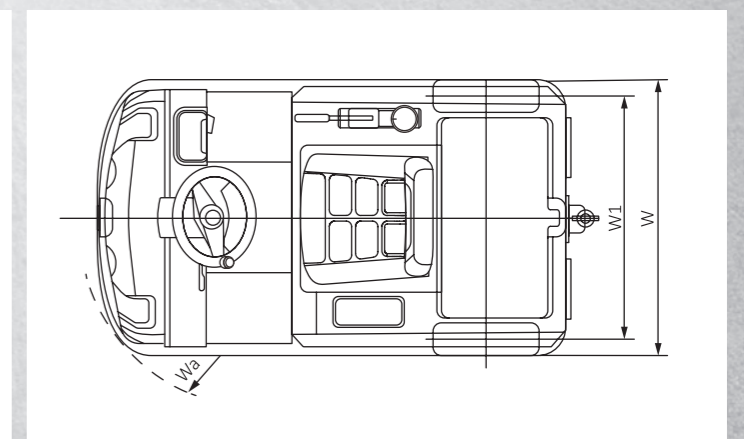
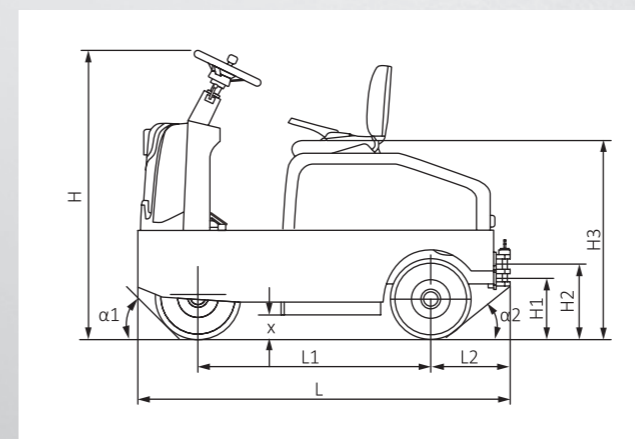



# HYSTER® DEALERS

Contact your nearest Hyster® Dealership  
by visiting [www.hyster.com.au](http://www.hyster.com.au)



## HYSTER PACIFIC

1 Bullecourt Avenue, Milperra NSW, Australia 2214  
Tel: +61 (2) 9795 3800 Fax: +61 (2) 9792 8484  
[hyster.com/pacific/en-au](http://hyster.com/pacific/en-au)

## HYSTER ASIA

16 Tuas Avenue 20, Singapore 638827  
Tel: +65 6863 3387 Fax: +65 6863 3349  
[hyster.com/asia/en-sg](http://hyster.com/asia/en-sg)



/Hysterasiapacific



HysterJAPIC



Hyster Asia-Pacific