



WWW.HYSTER.COM

ELECTRIC WALKIE PALLET TRUCK

PRODUCT BROCHURE



P30UT

P30UT OVERVIEW

The Hyster® electric walkie pallet truck P30UT combines ergonomic features and reliable performance with energy efficient technology. Low maintenance delivers increased productivity and reduced operational costs.

Productivity

- Small turning radius 57.2" (1454 mm)
- Performs well on gradients
- Long handle helps reduce steering effort
- Turning radius is reduced when operating with the tiller in the upright position
- Pallet entry rollers help forks glide in and out of pallets
- Variable speed control
- Built in charger
- Low speed switch in the handle
- Floating balance wheel automatically adjusts height and helps improve stability when unloading

Safety Features

- Emergency stop button
- Emergency reversing belly button
- Casters to help increase stability

Optimum Structural Design

- Formed heavy gauge steel provides maximum fork strength and longevity
- Pull rod design protects against bending
- Durable plastic covers
- Compact and lightweight design

Serviceability

- Fast and efficient servicing
- Simple components
- Computer-based diagnostics not required
- Sealed maintenance free batteries
- Tandem wheel option available



Handle (standard)
(left and right handed)



Entry roller for easy
operation

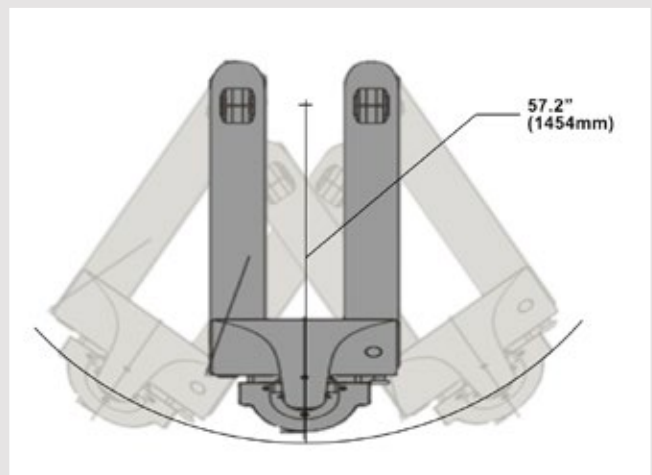

Small turning radius

SPECIFICATIONS AND DIMENSIONS

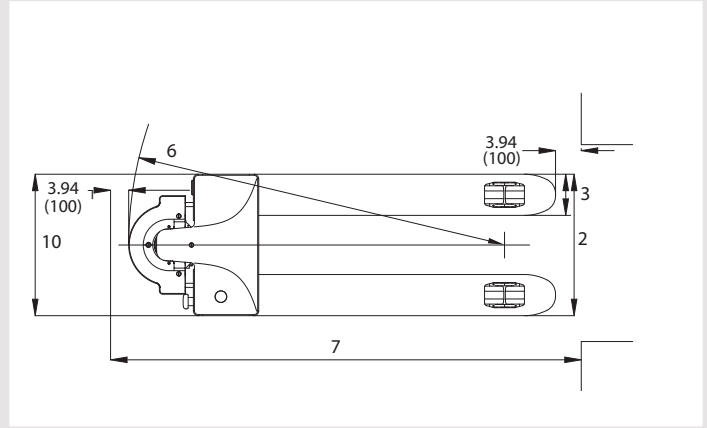
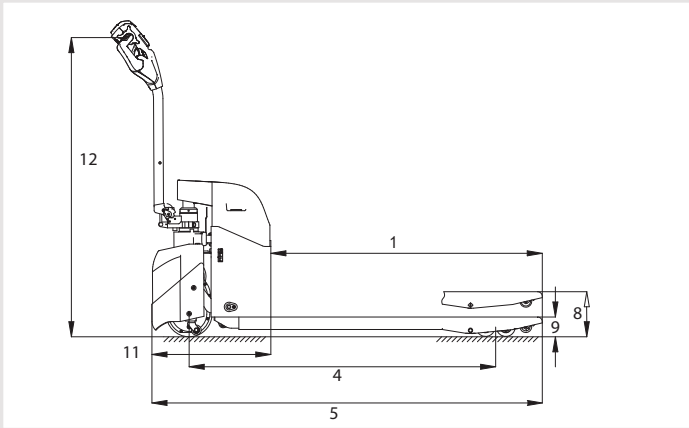

MODEL		P30UT
Power type		24-volt
Operator type		Pedestrian
Rated capacity	lb (kg)	3,300 (1,500)
Load center	in (mm)	23.6 (600)
Fork length	[1] in (mm)	45.28 (1,150)
Fork overall width	[2] in (mm)	26.97 (685)/20.47 (520)
Fork width (individual fork)	[3] in (mm)	6.30 (160)
Wheelbase (raised/lowered)	[4] in (mm)	50.67 (1,287)/53.42 (1,357)
Overall length	[5] in (mm)	65.11 (1,654)
Outside turning radius (raised)	[6] in (mm)	57.24 (1,454)
Right angle stack (39.37 x 47.24 crossways)	[7] in (mm)	73 (1,854)
Overall lift height - top of forks	[8] in (mm)	7.48 (190)
Lowered height - top of forks	[9] in (mm)	2.95 (75)
Total lift	in (mm)	4.52 (115)
Truck overall width	[10] in (mm)	26.97 (685)/22.12 (562)
Chassis length	[11] in (mm)	19.84 (504)
Height of tiller (max.)	[12] in (mm)	50 (1,270)
Battery compartment - standard	in (mm)	8.97 (228)/5.43 (138)/8.42 (214)
Maximum gradeability (loaded/unloaded)	%	5/10
Maximum travel speed (loaded/unloaded)	mph (km / h)	2.7 (4.3)/3 (4.8)
Traction motor control method type		DC
Service brake type		Electric
Truck weight (approximate) with battery - NL/RL	lb (kg)	451.95 (205)/3,758.9 (1,705)
Drive tire - size type (number of wheels)	in (mm)	ø7.68 (195) x 2.75 (70) poly (1)
Load wheel - size/type (number of wheels)	in (mm)	ø2.91 (74) x 3.54 (90) poly single/ø2.91 (74) x 2.75 (70) poly tandem
Battery type		Sealed
Battery ampere hours	Ah	65
Battery weight	lb (kg)	79.37 (36)
On board charger	V	100-240
Battery ampere hours	Ah	400
Battery weight	lb (kg)	1,499 (680)
Sound level at the drivers ear according to EN/DIN 12 053	dB (A)	<68



Hyster Company
P.O. Box 7006, Greenville, North Carolina 27835-7006

© Hyster Company. 2023, all rights reserved. Hyster and  are trademarks of Hyster-Yale Group, Inc.
Hyster products are subject to change without notice. Trucks may be shown with optional equipment.