

WWW.HYSTER.COM

WALKIE LOW LIFT PALLET TRUCK

PRODUCT BROCHURE

W45ZHD2







STRONG AND INTELLIGENT

Volume is key in any warehousing or retailing application. Hyster Company can help you boost yours with the W45ZHD2 walkie pallet truck. Designed to be tough, the walkie pallet truck series is also intelligent. Its exceptional maneuverability, ergonomics and performance stems from innovative design and engineering. With a vast array of option combinations and standard features, the W45ZHD2 enables operators to move loads as safely, quickly and efficiently as possible at every stage of pallet handling.

DEPENDABILITY

Hyster® W45ZHD2 walkie pallet trucks are designed and manufactured to be among the most dependable trucks in the industry today. Because this truck is designed for strength, dependability and long wear, they're also on the job more — exactly where you want your trucks and operators to be.

BACKBONE OF STRENGTH AND DURABILITY

By designing the frame of the truck to better engage and support the pallet, Hyster increased the stability of the truck with a load. Hyster has integrated drive unit mounting, linkage mounting, and hydraulic cylinder mounting, improving durability and reliability for the life of the truck.

The W45ZHD2 combines a heavy duty steel drive frame with a highly engineered drive unit casting, making this one of the heaviest drive unit frames in the industry. Optimally placed as the backbone of the truck, the two create a strong drive end. The heavy duty casting replaces fabricated components for increased strength and durability, and concentrates all of the forces of the truck to an intelligent, highly engineered component.







PROTECTED COMPONENTS

- The cover of the W45ZHD2 is comprised of a highly durable, engineered thermoplastic elastomer. It is flexible, resistant to chipping, and gives full protection of components, unlike metal covers of some competitors.
- The charger is enclosed within the drive frame, protected from the harsh elements.
- The motor remains stationary during steering, protecting power cables from wear and strain.
- Enclosed, vertical mounted AC drive motor is easily accessed and is protected from splashes and debris.

TESTED AND PROVEN APPLICATION RESULTS

Each component of the W45ZHD2 walkie has been engineered and tested to provide a high level of dependability. Hyster has tested those components against competitors to make sure you're operating a strong, durable lift truck.

13 LETS HOUR 	7% LESS ENERGY USAGE	11% MORE PRODUCTIVE UNLOADING TRAILERS* 	 2X THICKER BUSHINGS	 1 BILLION POUNDS LIFTED WITHOUT FAILURE	 100,000 FULL CAPACITY (C) WITHOUT LINI SYSTEM FAIL
---	--------------------------------	--	--	---	--

*with standard features

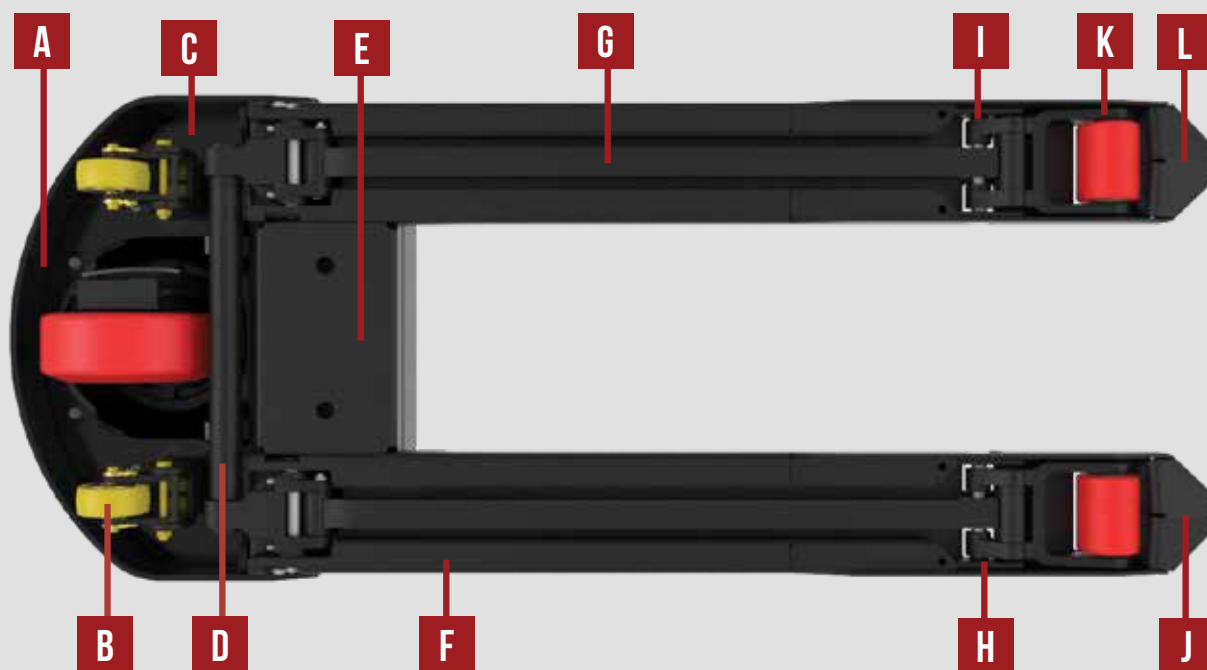

- A** Robust 3/8" welded bumper components are mounted to the back plate.
- B** Optional casters and tabs reduce product damage and aid in extra stability when required for certain applications.
- C** Heavy duty drive frame increases stability and dependability.
- D** Heavy duty torsion bar and casted yokes helps stability and equalized loading.
- E** Integrated fork torsion box for increased fork stiffness and torsional stability.
- F** Heavy duty thick boxed-in C-channel fork body.
- G** Industry's strongest pull rod design.
- H** Strong, hardened flagged linkage pins at all connections.
- I** "X" groove bushings and lubrication points at all linkage connections.
- J** Pallet entry/exit design integrated into fork structure.
- K** Casted load wheel links with multiple load wheel options.
- L** Boxed-in fork tips designed for strength and optimized for maneuverability.

DEPENDABILITY

Hyster has focused our efforts to build a truck that can stand up to the challenges of your operation. When your application demands a heavy duty truck, you want to be absolutely certain you have the equipment that's up to the task. That's why we built the Hyster® W45ZHD2 walkie to be one of the toughest, most intelligent and most reliable in the industry.

DESIGNED AND BUILT TO SAVE YOU MONEY

- Heavy duty torsion bar helps to create a more uniform loading of pins and linkage rods reducing wear and tear, increasing durability and reliability, and extending life.
- The linkage rod is comprised of a uniform square bar with welded ends for maximum strength and low maintenance.
- Bushings are the thickest bronze bushings available and provide the most contact area, resulting in improved distribution of force and increased service life. The proven "X" groove design allows for full spread of lubrication throughout bushing, minimizing wear.
- Steel drive frame enhances stability and durability, decreasing service costs and damage to loads.
- For applications where even more stability is needed, optional casters have been reinforced with heavy duty casting. Coil springs have been replaced with poly block which is more durable and resistant to corrosion, reducing cost and service requirements.
- Large, maintenance-free turntable steer bearings distribute and handle driving and steering forces better than small taper bearings, lowering cost of ownership.
- AC traction motor is maintenance-free and external speed sensor is easy to access, reducing cost of maintenance.



SERVICEABILITY

Even the toughest trucks need to be properly maintained, so when it comes time to service your W45ZHD2 walkie, we've made certain it's easy to get the job done fast. The easy-to-remove cover, provides convenient access to main components. Lube fittings at all major linkage points are highly accessible to provide easy maintenance and long service life. Flag pins throughout the linkage system enable pins and bushings to be easily serviced.

When equipped with an on-board charger, the W45ZHD2 pallet truck features a unique charge port, conveniently mounted to the front of the truck for easy access. The charge port removes the need for the operator to go into the battery compartment.

BRUSHLESS AC TECHNOLOGY

- The W45ZHD2 incorporates an AC transistorized traction controller
- AC technology means no brushes to service, no wear items.
- Requires no periodic maintenance.
- Eliminates scheduled downtime and the cost for parts and service.
- Eliminates the service requirements created by brush wear and dust.



SUPPORTING CUSTOMERS WITH WORLD-CLASS PARTS & SERVICE

Four Parts Distribution Centers strategically located around the world provide a full range of original equipment and aftermarket parts that help maintain our customers' uptime. In fact, our Guaranteed Availability Program provides that parts that are normally required in the first 2 years of operation will be available from your Hyster® parts dealer within 24 hours or they are free.*

We also take that commitment into the field with the Hyster CERTECH® Certification training program. This technical training program provides both systems level as well as product-specific education to help with repairing lift trucks.

* Contact your local dealer for program details.

EXCEPTIONAL ERGONOMICS

TOUGH ON THE INSIDE, INTELLIGENT ON THE OUTSIDE.

The productivity of your operation is directly affected by the comfort of your operators. We've always engineered Hyster® trucks to be operator friendly and our walkies are no exception. From the mid-mounted, shortened handle to the vertically mounted drive motor assembly, our intelligently designed ergonomics make the W45ZHD2 walkie pallet truck easy and comfortable to operate.

GREAT VISIBILITY

The operator interface with pallet load is very important for a pedestrian walkie truck. The W45ZHD2 allows the operator to see the forks, place them, and enter and exit a pallet whether it is empty or loaded.

Through experienced engineering and design focused on the operator, the W45ZHD2 has the best visibility in its class. Tests proved that visibility was well-suited for most operators. Superior visibility means you save time and increase productivity throughout your operation.

REDUCED OPERATOR EFFORT

- The tiller has a light hold down effort. Little exertion is needed by the operator to move the handle to the run zone and easily maintain its position there.
- The mid-mounted control handle placement has been designed to balance the constraints of steer effort, visibility and maneuverability.
- Large turntable bearing and standard rubber tire reduce the force required to turn the steer tire. The less energy the operator must use to steer the truck the more efficiently the pallet will be moved.





CONTROL HANDLE

The shortened, mid-mounted handle moves the operator closer to the truck, maximizing both visibility and maneuverability. Our W45ZHD2 truck has one of the largest run zones in the industry, enabling the truck to be operated comfortably by a wide variety of operators.

The turtle function allows the truck to function with the handle in full upright position as well as in the run position for maneuvering in tight spaces. The feature can be easily activated in all handle positions which allows the operator to turn the turtle function on and off while operating the truck.

The ergonomically designed handle minimizes wrist movement and provides a solid grip for additional control while operating the unit in all applications. Lift, lower, and horn push buttons are conveniently located at the operator's fingertips for easy access without having to release the hand from the grip. The butterfly throttle control provides a high level of controllability when selecting direction and speed, minimizing operator fatigue.



Largest run zone in the industry allows for comfortable operation.



Ergonomically designed control handle.



The W45ZHD2 with factory installed batteries includes an operator convenience tray with large storage area for stowing clipboards, pens, pencils and other items. Units equipped with a 9" battery box have several convenience tray options. (9" battery box option shown)

EFFICIENCY EQUALS PRODUCTIVITY

With its small footprint and ability to transport pallets in compact areas, the W45ZHD2 means your operator will have confidence operating in congested situations. It's a simple fact of your business that you need to move your product quickly and efficiently with minimum downtime. The W45ZHD2 helps you do just that with several exclusive productivity-enhancing features.

HYSTER INTELLIGENT LIFT™

You've got to move loads—we understand that. Holding the lift button and waiting for the pallet to lift is time you don't have. That is why we created the exclusive Hyster Intelligent Lift™ to increase the operator's productivity.

Hyster Intelligent Lift™ enables the operator to start transporting the pallet before the unit is at full lift. The W45ZHD2 equipped with this option will automatically lift the pallet to maximum fork height without having to continually hold the lift button. As a result of the simultaneous action of lifting and traveling, Hyster Intelligent Lift™ can reduce cycle times by up to 25%, increasing productivity.

TURTLE FUNCTIONALITY

The unit can be engaged in turtle function at any position in the run zone. When the handle is in the run zone, and the turtle functionality is selected, the W45ZHD2 latches into turtle mode which slows the speed and acceleration of the truck, giving the operator greater confidence in congested applications.

When the handle is in the upper brake zone the operator can press and hold the turtle button to maneuver the truck. This minimizes the truck profile, improving maneuverability inside trailers. Turtle functionality is especially effective when the application requires pinwheeling loads.



DESIGNED FOR PERFORMANCE

Hyster Company has shortened the fork tip length of the W45ZHD2 and designed a low-profile bumper to provide a tight right angle turn for easier right angle stacking, equal aisle placement, and improved maneuverability within a trailer. Fork tips feature a tapered fork nose and blunt ends to allow for repositioning of pallets and enhances pallet entry. The design is ideally suited for pinwheeling applications which allows the customer to put 10% more pallets on each truck, reducing per pallet transportation costs.

STABILITY IS KEY

A stable truck creates confidence in your operator. Hyster focused on several areas to add to the stability of our trucks. First, we reinforced the frame to get increased torsional stiffness. We then implemented a heavy duty torsion bar and linkage, which all work together to reduce torsional twisting, making the W45ZHD2 one of the most stable walkies in the industry.



Hyster Intelligent Slow Down™ Sensor

HYSTER INTELLIGENT SLOW DOWN™

The Hyster® W45ZHD2 truck features optional Hyster Intelligent Slow Down™ technology to help with the stability of every load. This exclusive feature recognizes when the truck is turning and intelligently reduces the truck's speed, assisting the operator through the corner. This enables the operator to maneuver through the warehouse with confidence, giving the W45ZHD2 best-in-class stability.

HYSTER® VARIABLE POWER TECHNOLOGY™

Hyster® Variable Power Technology™ provides adjustable performance modes that allow customers to maximize productivity or fuel economy to fit their specific application requirements. With selectable performance modes, the W45ZHD2 series can be tailored to achieve a balance of enhanced performance and superior fuel economy, or to maximize productivity during peak business periods when moving more loads is integral to the success of your operation.

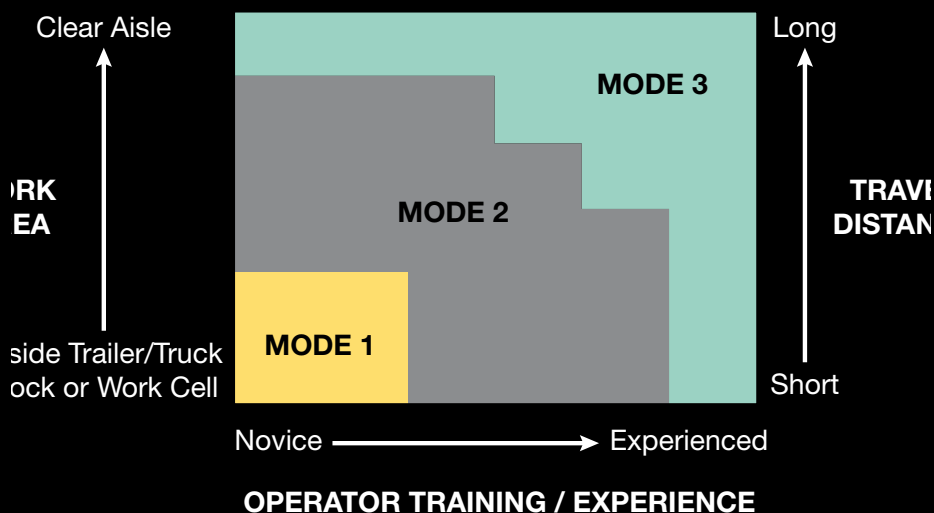

Mode 1 – new operator, inside trailer, short distances, or for improved battery life

Mode 2 – operator with more experience, larger work area, medium runs

Mode 3 – experienced operator, large work area, longer travel distances

CUSTOMIZED PERFORMANCE FOR ANY APPLICATION

Tough applications come in all shapes and sizes. That's why Hyster Company gives you the option of tailoring your lift truck's performance and features to your application. Customize speed settings and choose from a wide array of options and accessories.



MOVABLE LOAD BACKREST

The movable load backrest option is a convenient option available for use in relevant applications, such as the beverage industry. The load backrest extends further toward the fork tips in order to accommodate 36" and 48" pallets. The backrest features 3 secure points of attachment, as well as a simple locking mechanism.

APPLICATION / ENVIRONMENTAL CONSTRUCTION

Standard Construction

Operating Temperatures: +32°F to +120°F

Cooler/Freezer Package

Operating Temperatures: 0°F to +120°F
(Red Polyurethane Groove or Rubber Drive Tire Recommended)

SubZero Freezer Package

Operating Temperatures: -40°F to +120°F
(Red Polyurethane Groove or Rubber Drive Tire Recommended)

Wash Down Package: Includes electric brake enclosure, lubrication (hydraulic freezer oil) and corrosion inhibitor on unpainted surfaces of drive wheel and drive unit.

Operating Temperatures: 0°F to +120°F
(Red Polyurethane Groove or Rubber Drive Tire Recommended)

Heavy Corrosion Wash Down Package: Includes galvanized frame and lift linkage, electric brake enclosure, lubrication (hydraulic freezer oil) and corrosion inhibitor on unpainted surfaces of drive wheel and drive unit.

Operating Temperatures: 0°F to +120°F
(Red Polyurethane Groove or Rubber Drive Tire Recommended)

Note: Stainless steel load wheel bearings recommended with Wash Down and Heavy Corrosion Wash Down packages.

INNOVATIVE POWER OPTIONS

Lithium-Ion Advanced Performance Power System

The 57 Ah lithium-ion battery pack is completely sealed and maintenance free. The 5+ year lifespan results in fewer battery replacements over the life of the truck. A shorter, more compact 6" battery compartment enhances the unit's performance in congested areas and tight spaces.

The cell construction design is ideal for applications where vibration or contamination issues are a concern. No equalization charge is required, and opportunity charging is performed with no negative effect. The lithium-ion battery pack comes with a 60 month/10,000 hour warranty.

Wet-Cell 4-Pack

170 Ah battery pack comes with (4) 6V wet-cell batteries.

AGM 4-Pack

187 Ah AGM pack is by far one of the best in the industry in terms of power and life. The maintenance free option has been optimized specifically to work with the charger to create one of the best power options on the market.

Industrial Battery

Hyster offers dealer installed 12-85-7 industrial batteries for the W45ZHD2. As a result, your truck will be able to handle the rigors of a high duty cycle application.



Lithium-Ion battery**



AGM battery



Wet-cell battery

** 57Ah lithium-ion battery shown



DELIVERY HANDLE OPTION

Because Hyster recognizes the unique challenges in direct store delivery applications, we designed a unique retail delivery handle option for the W45ZHD2. The ergonomically designed handle gives the operator full command of the truck's functionality with the handle in the full upright position and while moving at Creep Speed. Consequently, the operator can move closer to the truck to operate in the most compact of areas, such as a retail store, crowded trailer, or on the end of a tailgate.



XTRA
U33971

HYSTER

THINK
A FIRE TRAP
NO JETS
TOMORROW
NO
SMOKING

INNOVATIVE TRUCKS ENGINEERED TO MEET THE MOST DEMANDING APPLICATIONS

For more than 80 years, Hyster has been conquering the world's most demanding applications. In the 1920's Hyster started as a manufacturer of lifting machines used in the rigorous logging industry of the Pacific Northwest in the United States. A few years later the first forklift trucks were invented and the Hyster brand quickly gained its reputation for rugged quality. Hyster® lift trucks are designed to lower your cost of operations. Every truck we make — gasoline, LPG, diesel and electric — is purpose-built to excel in its application. Every truck is also backed by an unmatched network of specialists.



Dealer Network — Our Dealer Network can offer the expertise of fleet managers, parts suppliers, capital procurement specialists and trainers. Carefully chosen dealers fully understand customer applications, assist in selecting the right lift truck and provide fast, reliable support.



Hyster Fleet Services — Even if you operate other brands, we can manage your maintenance and replacement plan. We can offer complete fleet analysis, fleet history summary and a cost-effective proposal for replacement and scheduled maintenance.



Parts — With genuine Hyster® replacement parts and UNISOURCE™ parts for all makes of lift trucks, we are your one-stop source for lift truck parts. In fact, we offer more than 7 million part number crosses for most brands of materials handling and other in-plant mobile equipment.



Rental Products — When leasing or buying isn't a practical option, we have access to more than 14,000 units for short- and long-term rental. We'll help you maintain output in a cost-effective manner.



Hyster Capital — We can arrange solutions for special financing requirements, taking the difficulties out of buying the equipment you need. Whether you purchase or lease a new or used lift truck, Hyster Capital offers superior service and competitive rates.



Special Products Engineering Department (SPED) — Different materials require different handling. That's why we can work with you to customize your lift trucks. From strobe lights to specially made forks, SPED has the tools to help you get the job done right.



Operator Training — Proper education in operating lift trucks minimizes the risk of injuries due to accidents while increasing productivity. Hyster offers OSHA-compliant materials that support the training of qualified operators.



Service — Your local Hyster® dealer offers a flexible, customized and comprehensive maintenance plan based on each lift truck's operation environment. Hyster service programs offer scheduled inspections and maintenance, along with quick, responsive service dispatched to your location.



Hyster Pacific

1/23 Rowood Road, Prospect NSW 2148

Tel: +61 (2) 9795 3800 Fax: +61 (2) 9792 8484

Hyster Asia

16 Tuas Avenue 20, Singapore 638827

Tel: +65 6863 3387 Fax: +65 6863 3349

Visit us online at www.hyster.com

© Hyster Asia Pacific 2023. All rights reserved. HYSTER, , and Strong Partners. Tough Trucks are trademarks of Hyster-Yale Group, Inc. Specifications and details in this brochure are subject to change without prior notification. Please consult with your Hyster dealer for the most up to date information and to confirm exact capacities.