

C60-80Z^{HD} SERIES

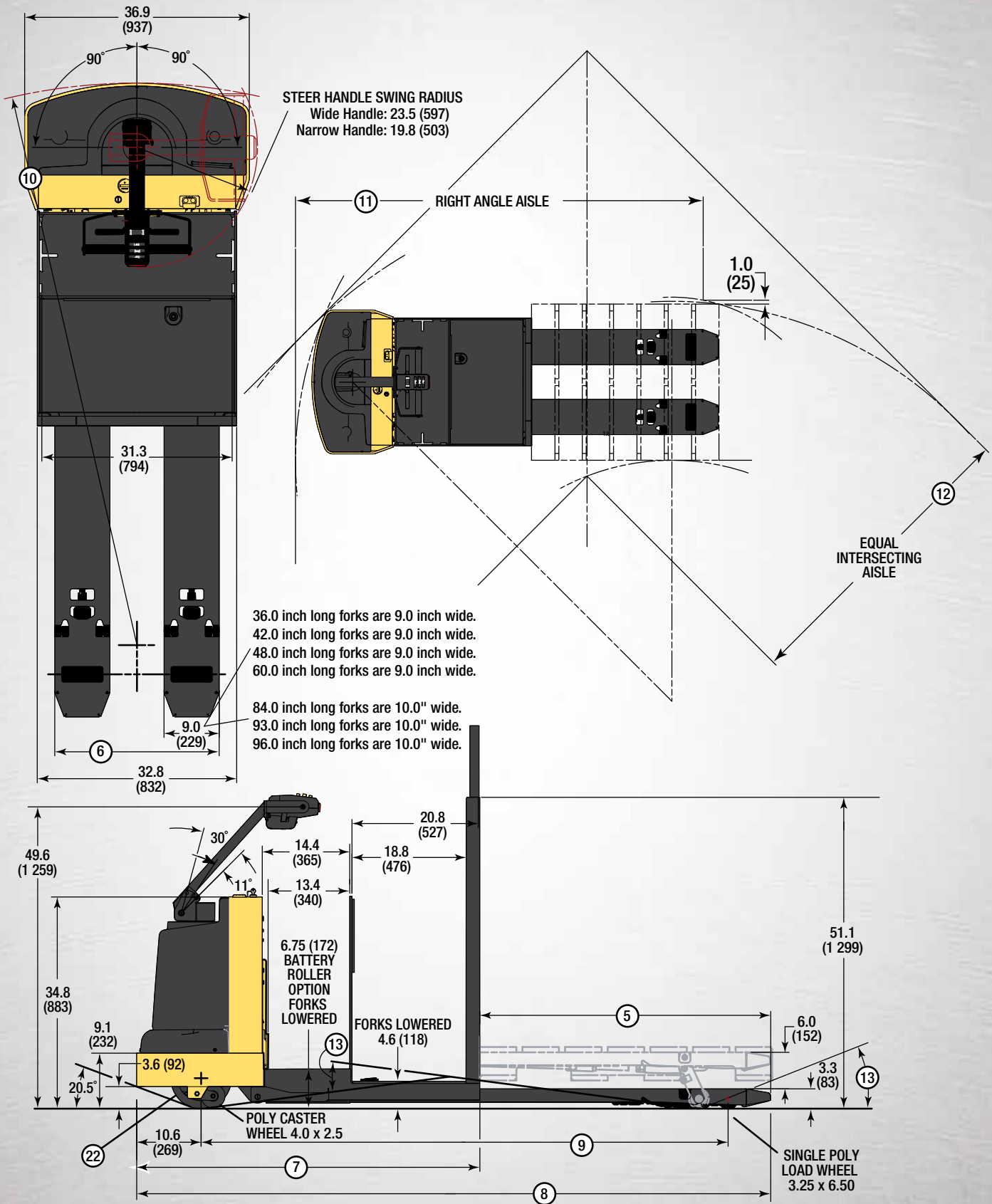

TECHNICAL GUIDE
Heavy-Duty Forklift Truck

C60-80Z^{HD} DIMENSIONS



Dimensions are in inches (millimeters).

C60Z^{HD} SPECIFICATIONS

GENERAL	1	Manufacturer	Hyster Company			
	2	Model	C60Z ^{HD}			
	3	Capacity, rated	lbs. (kg)	6,000 (2722)		
	4	Voltage	24			
DIMENSIONS	5	Nominal fork length	in. (mm)	36.0 (914)	48.0 (1219)	60.0 (1524)
	6	Width across forks	in. (mm)	27.1 (688)		
	7	Chassis length w/std. 13.4" battery compartment	in. (mm)	58.9 (1496)		
	8	Overall length, w/std. 13.4" battery compartment	in. (mm)	94.6 (2404)	106.6 (2709)	118.7 (3014)
	9	Wheelbase, lowered w/13.4" battery compartment	in. (mm)	76.0 (1932)	88.0 (2236)	100.1 (2541)
		Wheelbase, raised w/13.4" battery compartment	in. (mm)	72.2 (1834)	84.2 (2139)	96.2 (2444)
	10	Turning radius, lowered, w/13.4" batt. cpmt/ wide handle	in. (mm)	90.7 (2304)	102.6 (2607)	114.3 (2903)
		Turning radius, raised, w/13.4" batt. cpmt/ wide handle	in. (mm)	87.0 (2209)	98.9 (2512)	110.5 (2807)
	11	Right angle aisle, w/13.4" battery compartment ^{††}	in. (mm)	96.0 (2438)	107.6 (2733)	119.8 (3042)
	12	Equal intersecting aisle, w/13.4" battery compartment ^{††}	in. (mm)	71.9 (1827)	78.2 (1987)	84.5 (2147)
	13	Grade clearance, center wheelbase, raised w/pallet	%	27	23	20
		Grade clearance, forks end, raised w/pallet	%	37		
	14	Overall lift height (TOF)	in. (mm)	9.25 (235)		
BATT.	17	Battery compartment size - std. 13.4", (L x W x H) *	in.	31.2 x 13.4 x Open		
		Battery compartment size - std. 13.4", (L x W x H) *	(mm)	(792 x 340 x Open)		
PERF. †	20	Travel speed, std. equipped truck No Load	mph (km/h)	9.0 (14.5)		
		Travel speed, std. equipped truck Rated Load	mph (km/h)	5.2 (8.4)		
	21	Lift / lower speed, No Load	seconds	3.3 / 1.9		
		Lift / lower speed, 6,000 lbs. Load	seconds	4.5 / 1.2		
WHEELS	22	Drive Tire Size (Polyurethane)	12.0 x 4.5 x 8.0			
	23	Load wheel size, tandem (Polyurethane)	(2 x) 3.25 x 6.50			
	24	Total approx. weight, 13.4" compartment - w/o battery	lbs. (kg)	1,807 (820)		

C60-80Z^{HC} pallet trucks use Red battery connector - 16" (406 mm) 1/0 gauge leads, B position.

* Length is measured side to side of truck.

†† Equal Intersecting Aisle and Right Angle Aisle Stacking dimensions are with standard GMA pallet(s) that measure 48.0" x 40.0".

CERTIFICATION: These Hyster lift trucks are designed to meet applicable regulatory codes and standards of OSHA, subpart n, Section 1910.178; ASME B56.1-1993, and current revisions; and U.L. 583 Standard of Electric Battery Powered Industrial Trucks.

† NOTE: Performance specifications are for truck equipped as described under Standard Equipment. Performance specifications are affected by the condition of the vehicle and how it is equipped, as well as the nature and condition of the operating area. If these specifications are critical, the proposed applications should be discussed with your local authorized Hyster dealer.

C60Z^{HD} BATTERY AND COMPARTMENT SPECIFICATIONS

NUMBER OF CELLS	CELL SIZE	PLATES PER CELL	CAPACITY AMP-HOURS	KWH	"X" DIMENSION in. (mm)	"Y" DIMENSION in. (mm)	"Z" DIMENSION in. (mm)	BATTERY WEIGHT lbs. (Kgs)
12	75	11	375	8.7	26.5 (673)	13.0 (330)	23.3 (592)	825 (374)
12	85	11	425	9.9	26.1 (663)	12.8 (325)	23.3 (592)	865 (392)
12	75	13	450	10.5	30.9 (785)	13.0 (330)	23.3 (592)	987 (448)
12	85	13	510	11.9	30.9 (785)	13.0 (330)	23.3 (592)	1,035 (469)

NOTES:

(1) Steel tray with cover required for all batteries.

(2) Battery connector type 175 Amp, Red.

(3) Cable lead position "B".

(4) 16" (406 mm) cable length.

(5) Maximum cable gauge of 1/0.

(6) Battery well: 31.25" x 13.4" x open (794 mm x 340 mm x open).

(7) Capacity noted is with 6 hr. rate.

(8) 24 Volt

C80Z^{HD} SPECIFICATIONS

GENERAL	1	Manufacturer	Hyster Company							
	2	Model	C80Z ^{HD}							
	3	Capacity, rated	lbs. (kg)	8,000 (3629)						
	4	Voltage	24							
DIMENSIONS	5	Nominal fork length	in. (mm)	36.0 (914)	48.0 (1219)	60.0 (1524)	84.0 (2134)	93.0 (2362)	96.0 (2438)	144 (3658)
	6	Width across forks	in. (mm)	27.1 (688)			27.9 (710)		28.6 (726)	
	7	Chassis length w/std. 13.4" battery compartment	in. (mm)	58.9 (1496)						
	8	Overall length, w/std. 13.4" battery compartment	in. (mm)	94.6 (2404)	106.6 (2709)	118.7 (3014)	142.6 (3622)	151.6 (3851)	154.6 (3927)	202.7 (5148)
	9	Wheelbase, lowered w/13.4" battery compartment	in. (mm)	76.0 (1932)	88.0 (2236)	100.1 (2541)	109.0 (2770)		136.1 (3456)	
		Wheelbase, raised w/13.4" battery compartment	in. (mm)	72.2 (1834)	84.2 (2139)	96.2 (2444)	105.2 (2672)		132.2 (3359)	
	10	Turning radius, lowered, w/13.4" batt. cpmt/ wide handle	in. (mm)	90.7 (2304)	102.6 (2607)	114.3 (2903)	123.3 (3132)		149.9 (3808)	
		Turning radius, raised, w/13.4" batt. cpmt/ wide handle	in. (mm)	87.0 (2209)	98.9 (2512)	110.5 (2807)	119.5 (3036)		146.1 (3712)	
	11	Right angle aisle, w/13.4" battery compartment ^{††}	in. (mm)	96.0 (2 413)	107.6 (2733)	119.8 (3042)	157.0 (3988)		207.2 (5262)	
	12	Equal intersecting aisle, w/13.4" battery compartment ^{††}	in. (mm)	71.9 (1827)	78.2 (1987)	84.5 (2147)	91.1 (2315)		107.4 (2727)	
13	Grade clearance, center wheelbase, raised w/pallet	%	27	23	20	18		14		
	Grade clearance, forks end, raised w/pallet	%	37			17	13	12	8	
14	Overall lift height (TOF)	in. (mm)	9.25 (235)				9.3 (235)			
BATT.	17	Battery compartment size - std. 13.4", (L x W x H) *	in.	31.2 x 13.4 x Open						
		Battery compartment size - std. 13.4", (L x W x H) *	(mm)	(792 x 340 x Open)						
PERF. †	20	Travel speed, std. equipped truck No Load	mph (km/h)	9.0 (14.5)						
		Travel speed, std. equipped truck Rated Load	mph (km/h)	5.2 (8.4)						
	21	Lift / lower speed, No Load	seconds	3.7 / 6.4						
		Lift / lower speed, 6,000 lbs. Load	seconds	5.4 / 2.4						
WHEELS	22	Drive Tire Size (Polyurethane)	12.0 x 4.5 x 8.0							
	23	Load wheel size, tandem (Polyurethane)	(2 x) 3.25 x 6.50			(2 x) 3.25 x 6.49		(2 x) 3.25 x 6.50		
	24	Total approx. weight, 13.4" compartment - w/o battery	lbs. (kg)	1,716 (778)	1,807 (820)	1,897 (860)	2,010 (912)	2,039 (925)	2,048 (929)	2,312 (1051)

C60-80Z^{HC} pallet trucks use Red battery connector - 16" (406 mm) 1/0 gauge leads, B position.

* Length is measured side to side of truck.

^{††} Equal Intersecting Aisle and Right Angle Aisle Stacking dimensions are with standard GMA pallet(s) that measure 48.0" x 40.0".

CERTIFICATION: These Hyster lift trucks are designed to meet applicable regulatory codes and standards of OSHA, subpart n, Section 1910.178; ASME B56.1-1993, and current revisions; and U.L. 583 Standard of Electric Battery Powered Industrial Trucks.

[†] NOTE: Performance specifications are for truck equipped as described under Standard Equipment. Performance specifications are affected by the condition of the vehicle and how it is equipped, as well as the nature and condition of the operating area. If these specifications are critical, the proposed applications should be discussed with your local authorized Hyster dealer.

C80Z^{HD} BATTERY AND COMPARTMENT SPECIFICATIONS

NUMBER OF CELLS	CELL SIZE	PLATES PER CELL	CAPACITY AMP-HOURS	KWH	"X" DIMENSION in. (mm)	"Y" DIMENSION in. (mm)	"Z" DIMENSION in. (mm)	BATTERY WEIGHT lbs. (kgs)
12	75	11	375	8.7	26.5 (673)	13.0 (330)	23.3 (592)	825 (374)
12	85	11	425	9.9	26.1 (663)	12.8 (325)	23.3 (592)	865 (392)
12	75	13	450	10.5	30.9 (785)	13.0 (330)	23.3 (592)	987 (448)
12	85	13	510	11.9	30.9 (785)	13.0 (330)	23.3 (592)	1,035 (469)
12	100	13	600	14.0	30.9 (785)	13.0 (330)	26.2 (665)	1,140 (517)
12	125	13	750	17.6	30.9 (785)	13.0 (330)	31.0 (787)	1,450 (658)

NOTES:

(1) Steel tray with cover required for all batteries.

(2) Battery connector type 175 Amp, Red.

(3) Cable lead position "B".

(4) 16" (406 mm) cable length.

(5) Maximum cable gauge of 1/0.

(6) Battery well: 31.25" x 13.4" x open (794 mm x 340 mm x open).

(7) Capacity noted is with 6 hr. rate.

(8) 24 Volt

FEATURES AND OPTIONS

STANDARD EQUIPMENT

- 24 volt
- AC traction controller
- Transistor hoist control
- Low battery lift interrupt without display
- Hyster I³ Technology™
 - Multifunction Display
 - o Battery State of Charge
 - o Hour Meter
 - o Low Battery Lift Interrupt
 - o Performance Mode Indicator
 - o Fault Indicator
- Lift motor cut-out at full height
- Key switch - molded soft key
- Battery compartment (31.3" x 13.4")
- 175 amp, Red battery connector
- Flush pallet stop
- 48.0" Long forks
- 3-Position tilt steer column
- Toggle switch activated, electro-mechanical park brake
- Floor mounted high speed switch
- Regenerative braking
- Standard construction
- 9.0" individual fork width, 27.0" width across forks
- 3.3" lowered fork height with 6.0" lift height
- Heavy-duty pull rods with replaceable threaded ends
- Single 3.25" x 6.50" polyurethane load wheels with 4-bearings per wheel
- Heavy Duty Casters – Quick Adjust Caster, 4" x 2.5"
- Electronic horn
- Full rotary grip travel control
- Polyurethane drive tire (12.0" x 4.5")
- 48.0" High load backrest extension / load support
- Operator's compartment (32.0" W x 20.8" D) with 1" thick cushioned floor mat and cushioned knee and back pad
- Operator manual
- 4.6" Operator's compartment step height (forks lowered)
- Lubrication fittings on undercarriage
- Control handle (25.0" overall width)
- U.L. Classification E
- On-Board Software
 - Program, Test and Diagnose
 - NO Handset Required
 - Password Protected
- Heavy Duty, Long Life Lift Linkage with Lubrication Fittings
 - "X" Groove Style Greaseable Pivot Bushings
 - Hardened, Bolt Retained Flag Linkage Pins
 - Knock-out Load Wheel Axles
- 12 Months / Unlimited Hour Manufacturer's Warranty
- 36 Months / 6,000 Hour Powertrain Warranty
- Lifetime Main Frame Warranty

OPTIONAL EQUIPMENT

- UL Classification Type EE
- Battery Rollers
- RF Terminal Power Supply – 24 Volt
- Audible Alarm – Self Adjusting Back Up Alarm
- Visible Alarm – Pole Mounted Amber Strobe
- Stability Casters
 - Heavy Duty – Sealed Wheel
- Fork Lengths
 - 36" Long Forks – Standard Tip
 - 60" Long Forks – Standard Tip
 - 84" Long Forks – Extended Tip
 - 93" Long Forks – Extended Tip
 - 96" Long Forks – Extended Tip
 - 144" Long Forks – Short Wheelbase Extended Tip (C80Z^{HD} only)
- Drive Tire
 - Soft Polyurethane – 80 Durometer, 12" x 4.5"
 - Red Polyurethane – 85 Durometer, 12" x 4.5"
 - Vulkollan Polyurethane – 90 Durometer, 12" x 4.5"
- Load Wheels
 - Single and Dual
 - 2 Bearing and 4 bearing
 - Standard Bearing and Sealed
- Load Backrest
 - 60" High Extension
 - 72" High Extension
- Premium Backrest
 - 3" Thick Backpad with Auxiliary Controls and Integral Armrest
- Application / Environmental Construction
 - Cooler / Freezer Package:
 - o Operating Temperatures: 0°F to +120°F
 - SUBZERO Freezer Package:
 - o Operating Temperatures: -40°F to +120°F
 - Wash Down Package:
 - o Operating Temperatures: 0°F to +120°F



Hyster Company
P.O. Box 7006
Greenville, North Carolina
27835-7006
Part No. C60-80ZHD/TG
7/2013 Litho in U.S.A.

Visit us online at www.hysteramericas.com or call us at 1-800-HYSTER-1.

Hyster and  are registered trademarks of Hyster Company.  is a trademark of Hyster Company. Hyster products are subject to change without notice.

The Hyster Company products included in this document may be covered by US Patent 6,684,148, and other patents pending. Truck on cover shown with optional equipment. ©2013 Hyster Company. All rights reserved.