



**STRONG PARTNERS.
TOUGH TRUCKS.™**



COMPACT STACKER

SC1.0

1 000 KG



SC1.0

DISTINGUISHING MARKS	1.1	Manufacturer (abbreviation)	
	1.2	Manufacturer's type designation	
	1.3	Drive: electric (battery or mains), diesel, petrol, fuel gas	
	1.4	Operator type: hand, pedestrian, standing, seated, order-picker	
	1.5	Rated capacity/Rated load	Q (t)
	1.6	Load centre distance	c (mm)
	1.8	Load distance, centre of drive axle to fork	x (mm)
	1.9	Wheelbase ▼	y (mm)

WEIGHTS	2.1	Service weight ▼	kg
	2.2	Axle loading, laden front/rear	kg
	2.3	Axle loading, unladen front/rear	kg

TYRES / CHASSIS	3.1	Tyres: polyurethane, tophane, vulkollan, front/rear	
	3.2	Tyre size, front	ø (mm x mm)
	3.3	Tyre size, rear	ø (mm x mm)
	3.4	Additional wheels (dimensions)	ø (mm x mm)
	3.5	Wheels, number front/rear (x = driven wheels)	
	3.6	Tread, front	b ₁₀ (mm)
	3.7	Tread, rear	b ₁₁ (mm)

DIMENSIONS	4.2	Height, mast lowered	h ₁ (mm)
	4.3	Free lift	h ₂ (mm)
	4.4	Lift	h ₃ (mm)
	4.5	Height, mast extended	h ₄ (mm)
	4.9	Height drawbar in driving position min./max.	h ₁₄ (mm)
	4.1	Height of wheel arms	h ₅ (mm)
	4.15	Height, lowered	h ₁₃ (mm)
	4.19	Overall length	l ₁ (mm)
	4.2	Length to face of forks	l ₂ (mm)
	4.21	Overall width	b ₁ /b ₂ (mm)
	4.22	Fork dimensions	s/e/l (mm)
	4.24	Fork-carriage width	b ₃ (mm)
	4.25	Distance between fork-arms	b ₄ (mm)
	4.31	Ground clearance, laden, below mast	m ₁ (mm)
	4.32	Ground clearance, centre of wheelbase	m ₂ (mm)
	4.33	Load dimension b ₁₂ × l ₆ crossways	b ₁₂ × l ₆ (mm)
	4.34.1	Aisle width for pallets 1000mm x 1200mm crossways	A ₁₁ (mm)
4.34.2	Aisle width for pallets 800mm x 1200mm lengthwise	A ₁₁ (mm)	
4.35	Turning radius	W ₃ (mm)	

PERFORMANCE DATA	5.1	Travel speed, laden/unladen	km/h
	5.1.1	Travel speed, laden/unladen, backwards	km/h
	5.2	Lift speed, laden/unladen	m/s
	5.3	Lowering speed, laden/unladen	m/s
	5.7	Gradeability, laden/unladen	%
	5.8	Max. gradeability, laden/unladen	%
	5.10	Service brake	

ELECTRIC ENGINE	6.1	Drive motor, S2 60 minute rating	kW
	6.2	Lifting motor, S3 15% rating	kW
	6.3	Battery according to DIN 43531/35/36 A,B,C, no	
	6.4	Battery voltage/nominal capacity K5	(V)/(Ah)
	6.5	Battery weight ▼	kg
	6.8	Energy consumption at turnover output	kWh in 1 h (kWh/h)

DRIVE/LIFT MECHANISM	8.1	Type of drive unit	
----------------------	-----	--------------------	--

ADDITIONAL DATA	10.7	Sound pressure level at the driver's seat	dB (A)
-----------------	------	---	--------

HYSTER		1.1
SC 1.0		1.2
Electric (battery)		1.3
Pedestrian		1.4
1		1.5
600		1.6
786		1.8
1165		1.9

371		2.1
434	937	2.2
269	102	2.3

Solid Rubber/Polyurethane	Polyurethane	3.1
186 x 50		3.2
82 x 70		3.3
125 x 45		3.4
1x + 1	2	3.5
505		3.6
410		3.7

1970		4.2	
1510		4.3	
1510		4.4	
1970		4.5	
930	1365	4.9	
80		4.1	
90		4.15	
1675		4.19	
522		4.2	
794		4.21	
60	150	1153	4.22
650		4.24	
560		4.25	
30		4.31	
40		4.32	
800 x 1200		4.33	
2130		4.34.1	
2120		4.34.2	
1344		4.35	

3.7	4.3	5.1
3.7	4.3	5.1.1
0.11	0.18	5.2
0.18	0.18	5.3
-	-	5.7
9	25	5.8
Electric		5.10

0.35		6.1
2.2		6.2
no		6.3
24	54	6.4
38		6.5
0.45		6.8

DC-Controller		8.1
---------------	--	-----

63		10.7
----	--	------

Specification data is based on VDI 2198

TRUCK DIMENSIONS

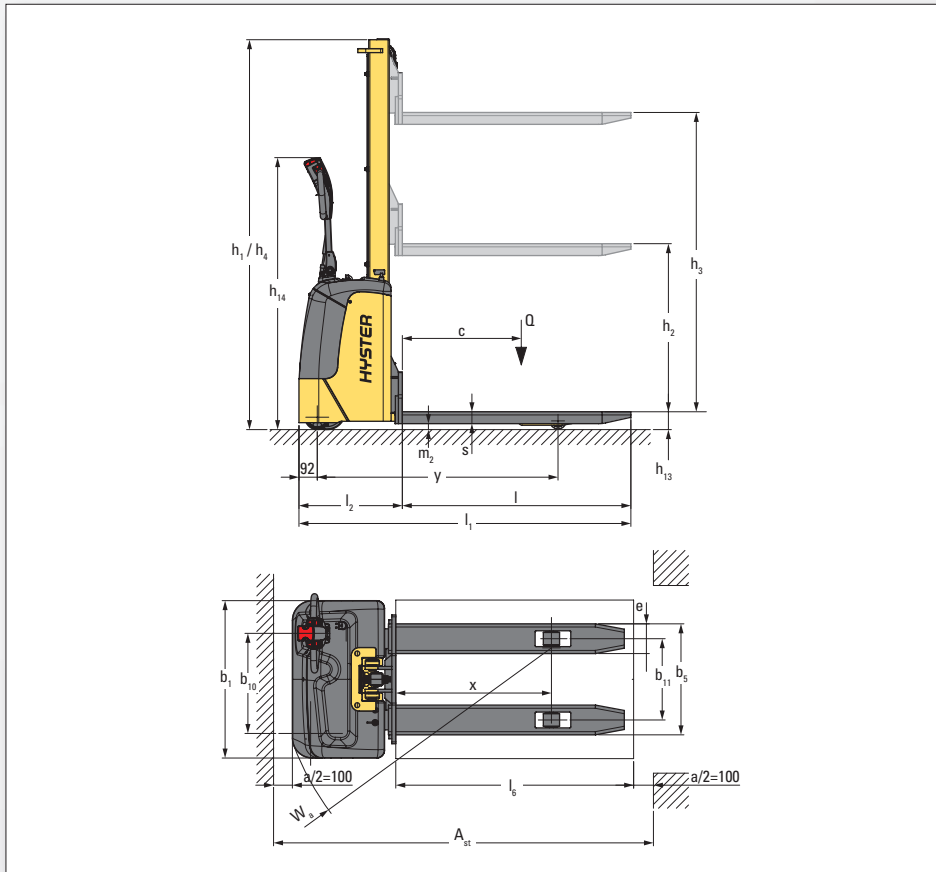

NOTE:

Care must be exercised when handling elevated loads. When the carriage and/or load is elevated, truck stability is reduced. It is important that the mast tilt in either direction is kept to a minimum when loads are elevated.

Operators must be trained and adhere to the instructions contained in the Operating Manual.

Hyster products are subject to change without notice. Lift trucks illustrated may feature optional equipment.

All values are nominal values and they are subject to tolerances. For further information, please contact the manufacturer.

Values may vary with alternative configurations.

▼ These values may vary of +/- 5%.

NOTICE

Care must be exercised when handling elevated loads. When the carriage and/or load is elevated, truck stability is reduced. It is important that the mast tilt in either direction is kept to a minimum when loads are elevated.

Operators must be trained and must read, understand and follow the instructions contained in the Operating Manual.

All values are nominal values and they are subject to tolerances. For further information, please contact the manufacturer.

Hyster products are subject to change without notice. Lift trucks illustrated may feature optional equipment. Values may vary with alternative configurations.

CE Safety:

This truck conforms to the current EU requirements.

PRODUCT FEATURES

DEPENDABILITY

- MOSFET DC controller for traction and hydraulic controls.
- Battery discharge indicator (Red - Amber - Green status).
- Welded fork construction makes them highly resistant to torsion and heavy loads
- In case of collision components and batteries are protected with special designed cover.

PRODUCTIVITY

- Compact chassis design to improve accessibility.
- Operator-friendly tiller head controls for productive load handling.
- Standard anti-roll back system.
- Stabilizing wheel to maximize stability when turning.
- Single load wheels.

ERGONOMICS

- Ergonomic tiller head designed for maximum operator comfort.
- Low effort controls ergonomically placed to reduce operator fatigue.
- Adjustable performance setting to suit specific operation conditions.
- Responsive butterfly switches give a smooth and controlled speed in either travel direction and allow controlled traction braking.
- Adjustable Creep-speed function for manoeuvring in dense areas – tiller arm in upright position or lowered.

LOW COST OF OWNERSHIP

- On board 10A HF charger for on-site recharge.
- Optimized battery packs to ensure maximum time of operation.
- Easy access to motor and key components to reduce downtime.

SERVICEABILITY

- Quick accessibility for exchange of batteries.
- Maintenance free sealed lead acid batteries.

STRONG PARTNERS. TOUGH TRUCKS.™

FOR DEMANDING OPERATIONS, EVERYWHERE.

Hyster supplies a complete range of warehouse equipment, IC and electric counterbalanced trucks, container handlers and reach stackers. Hyster is committed to being much more than a lift truck supplier.

Our aim is to offer a complete partnership capable of responding to the full spectrum of material handling issues: Whether you need professional consultancy on your fleet management, fully qualified service support, or reliable parts supply, you can depend on Hyster.

Our network of highly trained dealers provides expert, responsive local support. They can offer cost-effective finance packages and introduce effectively managed maintenance programmes to ensure that you get the best possible value. Our business is dealing with your material handling needs so you can focus on the success of your business today and in the future.



HYSTER EUROPE

Centennial House, Frimley Business Park, Frimley, Surrey, GU16 7SG, England.

Tel: +44 (0) 1276 538500



www.hyster.eu



infoeurope@hyster.com



[/HysterEurope](https://www.facebook.com/HysterEurope)



[@HysterEurope](https://twitter.com/HysterEurope)



[/HysterEurope](https://www.youtube.com/HysterEurope)



HYSTER-YALE UK LIMITED trading as Hyster Europe. Registered Address: Centennial House, Building 4.5, Frimley Business Park, Frimley, Surrey, GU16 7SG, United Kingdom. Registered in England and Wales. Company Registration Number: 02636775.

HYSTER,  and FORTENS are registered trademarks in the European Union and certain other jurisdictions.

MONOTROL® is a registered trademark, and DURAMATCH and  are trademarks in the United States and in certain other jurisdictions.

Hyster products are subject to change without notice. Lift trucks illustrated may feature optional equipment.