

E45-70XN2 SERIES



**4-WHEEL ELECTRIC
FORKLIFT TRUCK CUSHION TIRE**
Product Technical Guide



E45-70XN2 DIMENSIONS

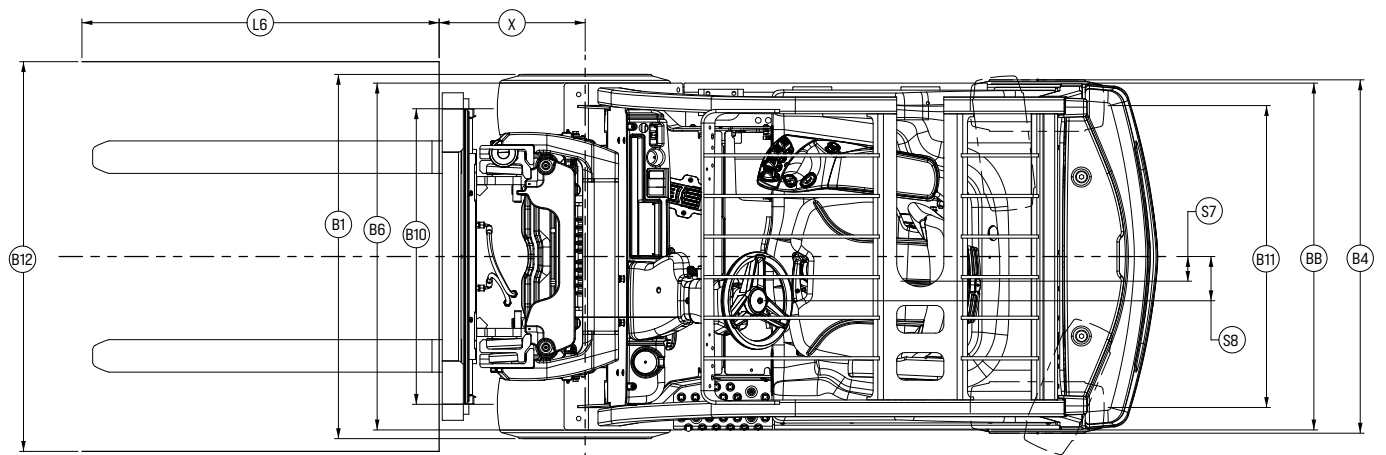

Circled dimensions correspond to the line numbers on the tabulated chart inside the technical guide.
Dimensions are in inches (millimeters).

E45-70XN2 DIMENSIONS

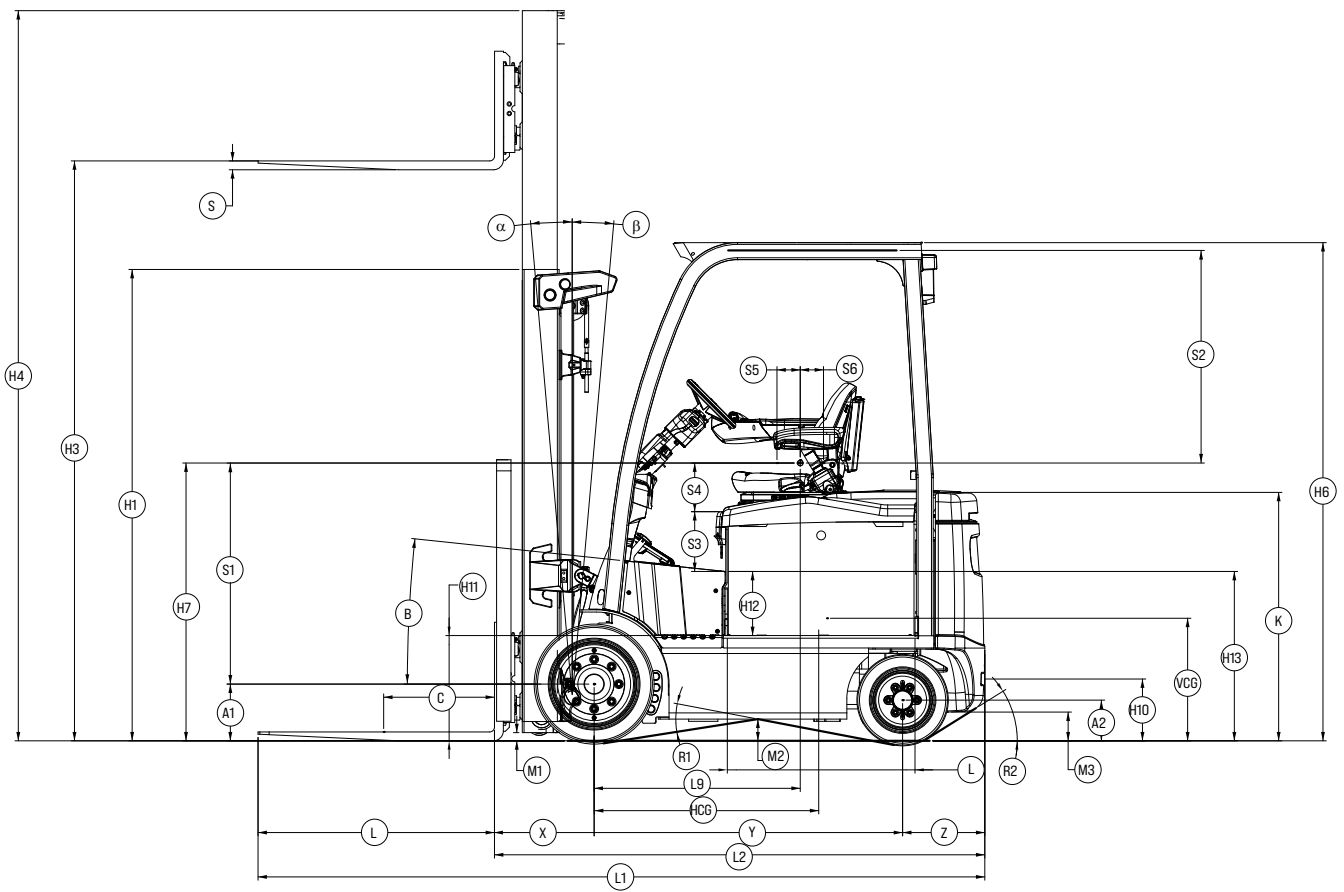

Circled dimensions correspond to the line numbers on the tabulated chart inside the technical guide.
Dimensions are in inches (millimeters).

E45XN2 SPECIFICATIONS

				Hyster			
				E45XN2			
GENERAL	1-1	Manufacturer		Hyster			
	1-2	Model Designation		E45XN2			
	1-2-1	Model		Standard			
	1-3	Drive: Electric (Battery Or Mains), Diesel, Gasoline, LPG		Electric (Battery)			
	1-4	Operator Type: Hand, Pedestrian, Standing, Seated, Order-Picker		Seated			
	1-5	Rated Capacity/Rated Load	Q	lb (kg)	4500 (2200)		
	1-6	Load Center Distance	c	in (mm)	24 (610)		
	1-8	Load Distance, Center Of Drive Axle To Fork	x	in (mm)	16.7 (425)		
		Battery Compartment Width		in (mm)	39.1 (992)		
		Battery Compartment Height (Without/With Battery Rollers)		in (mm)	23.9 / 23.4 (607 / 594)		
	Nominal Battery Compartment		in	27	30	33	
	Actual Battery Compartment		in (mm)	27.5 (700)	30.9 (786)	33.3 (847)	
1-9	Wheelbase (Short/Medium/Long)	y	in (mm)	49 (1245)	52.4 (1331)	54.8 (1392)	
WEIGHT	2-1	Service Weight (1)		lb (kg)	10562 (4790)	10390 (4712)	10816 (4906)
	2-2	Axle Loading Loaded, Front/Rear (1)		lb (kg)	12379/2683 (5616/1216)	12417/2472 (5632/1121)	12437/2879 (5641/1306)
	2-3	Axle Loading Unloaded, Front/Rear (1)		lb (kg)	4143/6419 (1879/2911)	4423/5967 (2006/2707)	4596/6220 (2085/2821)
WHEELS	3-1	Tires, Front/Rear		Cushion, Smooth			
	3-2	Tire Size, Front		21 x 7 x 15			
	3-3	Tire Size, Rear		16 x 5 x 10.5			
	3-5	Number Of Wheels, Front/Rear (X = Driven)		2x / 2			
	3-6	Tread, Front, Standard / Wide	b10	in (mm)	34.8 / 42.1 (883/1070)		
	3-7	Tread, Rear, Standard	b11	in (mm)	37.2 (945)		
	DIMENSIONS	4-1	Tilt Of Mast / Fork Carriage Forward / Backward	α / β	($^{\circ}$)	5 / 5	
4-2		Height, Mast Lowered	h1	in (mm)	83.9 (2132)		
4-3		Free Lift (2)	h2	in (mm)	3.9 (100)		
4-4		Lift (2)	h3	in (mm)	126.8 (3220)		
4-5		Height, Mast Extended (3)	h4	in (mm)	150.7 (3827)		
4-7		Height Of Overhead Guard (4)	h6	in (mm)	88.5 (2248)		
4-8		Seat Height Relating To Sip/Stand Height (5)	h7	in (mm)	48.5 (1233)		
4-12		Coupling Height	h10	in (mm)	11 (279)		
4-19		Overall Length	l1	in (mm)	122.4 (3108)	125.4 (3184)	127.8 (3245)
4-20		Length To Face Of Forks (6)	l2	in (mm)	80.4 (2041)	83.3 (2117)	85.7 (2178)
4-21		Overall Width, Standard / Wide	b1	in (mm)	42/49.1 (1068/1247)		
4-22		Fork Dimensions DIN ISO 2331	s/e/l	in (mm)	1.6 x 3.9 x 42 (40 x 100 x 1067)		
4-23		Fork Carriage Iso 2328, Class/Type A, B			II A		
4-24		Fork Carriage Width (7)	b3	in (mm)	38.4 (977)		
4-31		Ground Clearance, Loaded, Below Mast	m1	in (mm)	3.3 (84)		
4-32		Ground Clearance, Center Of Wheelbase	m2	in (mm)	3.9 (98)		
4-33		Load Dimensions B12 x L6 Crossways	b12/l6	in (mm)	47.2 x 39.4 (1200 x 1000)		
4-34-1		Right Angle Stack for pallets 48 in Long x 40 in wide (1219 x 1016) (8)	Ast	in (mm)	131.7 (3345)	133.6 (3394)	135.9 (3451)
4-35		Turning Radius	Wa	in (mm)	65.7 (1669)	67.7 (1720)	70 (1779)
4-36		Internal Turning Radius	b13	in (mm)	7.8 (198)	7.8 (198)	8.2 (208)
4-41	90° intersecting aisle with pallet 48" long x 40" wide (1219 x 1016)	W2	in (mm)	73.3 (1862)	73.9 (1878)	74.7 (1897)	
4-42	Step Height (From Ground To Running Board)		in (mm)	18.7 (475)	18.7 (475)	18.7 (475)	
4-43	Step Height (Between Intermediate Steps Between Running Board And Floor)		in (mm)	11.4 (289)	11.4 (289)	11.4 (289)	
PERFORMANCE	8-1	Drive Control		INTELMATCH			
		Battery Voltage/Nominal Capacity K5	V / Ah	AC Induction			
	5-1	Travel Speed, Loaded/Unloaded, Extended Shift Off (9)	mph (km/h)	36	48	Permanent Magnet	
	5-1-1	Travel Speed, Loaded/Unloaded, Extended Shift On (9)	mph (km/h)	9.7/10.6 (15.6/17.1)	11.3/11.0 (18.2/17.7)	12.4/12.1 (19.9/19.5)	12.5/12.2 (20.1/19.6)
	5-2	Lift Speed, Loaded/Unloaded, 2-Stg LFL	ft/min (m/s)	118/128 (0.6/0.65)	120/128 (0.61/0.65)	130/132 (0.66/0.67)	128/132 (0.65/0.67)
	5-2-1	Lift Speed, Loaded/Unloaded, 2-Stg FFL	ft/min (m/s)	108/118 (0.55/0.6)	110/118 (0.56/0.6)	120/122 (0.61/0.62)	118/122 (0.6/0.62)
	5-2-2	Lift Speed, Loaded/Unloaded, 3-Stg FFL	ft/min (m/s)	112/120 (0.57/0.61)	114/120 (0.58/0.61)	122/124 (0.62/0.63)	122/124 (0.62/0.63)
	5-2-3	Lift Speed, Loaded/Unloaded, 4-Stg FFL	ft/min (m/s)	106/114 (0.54/0.58)	108/114 (0.55/0.58)	116/118 (0.59/0.6)	118/118 (0.6/0.6)
	5-3	Lowering Speed, Loaded/Unloaded, 2-Stg LFL	ft/min (m/s)	108/128 (0.55/0.65)			
	5-3-1	Lowering Speed, Loaded/Unloaded, 2-Stg FFL	ft/min (m/s)	98/118 (0.5/0.6)			
	5-3-2	Lowering Speed, Loaded/Unloaded, 3-Stg FFL	ft/min (m/s)	102/120 (0.52/0.61)			
	5-3-3	Lowering Speed, Loaded/Unloaded, 4-Stg FFL	ft/min (m/s)	77/89 (0.39/0.45)			
	5-5	Drawbar Pull, Loaded / Unloaded, 60 Minute Rating **	LBF (N)	1832/1947 (8150/8660)	1956/2073 (8700/9220)	3419/3559 (15210/15830)	3478/3563 (15470/15850)
	5-6	Maximum Drawbar Pull, Loaded / Unloaded, 5 Minute Rating ***	LBF (N)	3669/3813 (16320/16960)	3745/3889 (16660/17300)	4346/4498 (19330/20010)	5694/5780 (25330/25710)
	5-7	Gradeability, Loaded / Unloaded, 30 Minute Rating **** (10)	%	17/25	16/25	28/25	29/25
5-8	Maximum Gradeability, Loaded / Unloaded, 5 Minute Rating **** (10)	%	25/25	26/25	30/25	41/25	
5-9	Gradeability, Loaded / Unloaded, 60 Minute Rating	%	12/20	13/21	23/25	24/25	
5-9	Acceleration Time, Loaded/Unloaded, 15m (9)	s	6.2/5.8	5.5/5.1	5.5/5.1	5.2/4.8	
5-10	Service Brake		Wet Disc - Oil Immersed				
ELECTRIC DRIVE	6-1	Drive Motor Rating S2 60 Min	Hp (kW)	2 x 11.8 (2x 8.8)		2x 12	
	6-2	Lift Motor Rating At S3 15%	Hp (kW)	26.9 (20.1)	26.9 (20.1)	29.1 (21.7)	28.8 (21.5)
	6-6	Energy Consumption According To DIN EN 16796 (11)	kWh/h	3.3	5.5	4.7	5.1
ADDITIONAL DATA	10-1	Operating Pressure For Attachments	bar	180			
	10-2	Oil Volume For Attachments (12)	gal/min (l/min)	10.6 (40)			
	10-3	Hydraulic Oil Tank, Capacity	gal (l)	5.6 (21.2)			
	10-7	Sound Pressure Level At The Driver's Seat (14) ANSI	dB (A)	71			
	10-8	Towing Coupling, Type DIN		Pin			

E50XN2 SPECIFICATIONS

				Hyster E50XN2			
GENERAL	1-1	Manufacturer		Hyster			
	1-2	Model Designation		E50XN2			
	1-2-1	Model		Standard			
	1-3	Drive: Electric (Battery Or Mains), Diesel, Gasoline, LPG		Electric (Battery)			
	1-4	Operator Type: Hand, Pedestrian, Standing, Seated, Order-Picker		Seated			
	1-5	Rated Capacity/Rated Load	Q	lb (kg)	5000 (2500)		
	1-6	Load Center Distance	c	in (mm)	24 (610)		
	1-8	Load Distance, Center Of Drive Axle To Fork	x	in (mm)	16.7 (425)		
		Battery Compartment Width		in (mm)	39.1 (992)		
		Battery Compartment Height (Without/With Battery Rollers)		in (mm)	23.9 / 23.4 (607 / 594)		
	Nominal Battery Compartment		in	27	30	33	
	Actual Battery Compartment		in (mm)	27.5 (700)	30.9 (786)	33.3 (847)	
1-9	Wheelbase (Short/Medium/Long)	y	in (mm)	49 (1245)	52.4 (1331)	54.8 (1392)	
WEIGHT	2-1	Service Weight (1)		lb (kg)	10939 (4962)	10748 (4875)	10721 (4863)
	2-2	Axle Loading Loaded, Front/Rear (1)		lb (kg)	13102/2836 (5943/1286)	13132/2615 (5957/1186)	13298/2422 (6032/1099)
	2-3	Axle Loading Unloaded, Front/Rear (1)		lb (kg)	3952/6987 (1793/3169)	4250/6498 (1928/2947)	4586/6135 (2080/2783)
WHEELS	3-1	Tires, Front/Rear		Cushion, Smooth			
	3-2	Tire Size, Front		21 x 7 x 15			
	3-3	Tire Size, Rear		16 x 5 x 10.5			
	3-5	Number Of Wheels, Front/Rear (X = Driven)		2x / 2			
	3-6	Tread, Front, Standard / Wide	b10	in (mm)	34.8 / 42.1 (883/1070)		
	3-7	Tread, Rear, Standard	b11	in (mm)	37.2 (945)		
	DIMENSIONS	4-1	Tilt Of Mast / Fork Carriage Forward / Backward	α / β	($^{\circ}$)	5 / 5	
4-2		Height, Mast Lowered	h1	in (mm)	83.9 (2132)		
4-3		Free Lift (2)	h2	in (mm)	3.9 (100)		
4-4		Lift (2)	h3	in (mm)	126.8 (3220)		
4-5		Height, Mast Extended (3)	h4	in (mm)	132.2 (3357)		
4-7		Height Of Overhead Guard (4)	h6	in (mm)	88.5 (2248)		
4-8		Seat Height Relating To Sip/Stand Height (5)	h7	in (mm)	48.5 (1233)		
4-12		Coupling Height	h10	in (mm)	11 (279)		
4-19		Overall Length	l1	in (mm)	123.3 (3131)	125.7 (3194)	127.8 (3245)
4-20		Length To Face Of Forks (6)	l2	in (mm)	81.3 (2065)	83.7 (2127)	85.7 (2178)
4-21		Overall Width, Standard / Wide	b1	in (mm)	42/49.1 (1068/1247)		
4-22		Fork Dimensions DIN ISO 2331	s/e/l	in (mm)	1.6 x 3.9 x 42 (40 x 100 x 1067)		
4-23		Fork Carriage ISO 2328, Class/Type A, B			II A		
4-24		Fork Carriage Width (7)	b3	in (mm)	38.4 (977)		
4-31		Ground Clearance, Loaded, Below Mast	m1	in (mm)	3.3 (84)		
4-32		Ground Clearance, Center Of Wheelbase	m2	in (mm)	3.9 (98)		3.8 (97)
4-33		Load Dimensions B12 x L6 Crossways	b12/l6	in (mm)	47.2 x 39.4 (1200 x 1000)		
4-34-1		Right Angle Stack for pallets 48 in Long x 40 in wide (1219 x 1016) (8)	Ast	in (mm)	132.8 (3374)	134.9 (3427)	135.9 (3451)
4-35		Turning Radius	Wa	in (mm)	66.9 (1698)	69 (1753)	70 (1779)
4-36		Internal Turning Radius	b13	in (mm)	7.8 (198)	7.8 (198)	8.2 (208)
4-41		90° intersecting aisle with pallet 48" long x 40" wide (1219 x 1016)	W2	in (mm)	73.6 (1870)	74.3 (1887)	74.7 (1897)
4-42		Step Height (From Ground To Running Board)		in (mm)	18.7 (475)	18.7 (475)	18.7 (475)
4-43		Step Height (Between Intermediate Steps Between Running Board And Floor)		in (mm)	11.4 (289)	11.4 (289)	11.4 (289)
PERFORMANCE	8-1	Drive Control		INTELMATCH			
		Battery Voltage/Nominal Capacity K5	V / Ah	DURAMATCH			
		Travel Speed, Loaded/Unloaded, Extended Shift Off (9)	mph (km/h)	AC Induction		Permanent Magnet	
	5-1	Travel Speed, Loaded/Unloaded, Extended Shift On (9)	mph (km/h)	36	48	48	80
	5-1-1	Travel Speed, Loaded/Unloaded, Extended Shift On (9)	mph (km/h)	9.7/10.6 (15.6/17.1)	11.3/11.0 (18.2/17.7)	12.4/12.1 (19.9/19.5)	12.5/12.2 (20.1/19.6)
	5-2	Lift Speed, Loaded/Unloaded, 2-Stg LFL	ft/min (m/s)	112/128 (0.57/0.65)	112/128 (0.57/0.65)	122/132 (0.62/0.67)	120/132 (0.61/0.67)
	5-2-1	Lift Speed, Loaded/Unloaded, 2-Stg FFL	ft/min (m/s)	102/118 (0.52/0.6)	104/118 (0.53/0.6)	112/122 (0.57/0.62)	112/122 (0.57/0.62)
	5-2-2	Lift Speed, Loaded/Unloaded, 3-Stg FFL	ft/min (m/s)	104/120 (0.53/0.61)	106/120 (0.54/0.61)	116/124 (0.59/0.63)	114/124 (0.58/0.63)
	5-2-3	Lift Speed, Loaded/Unloaded, 4-Stg FFL	ft/min (m/s)	100/114 (0.51/0.58)	100/114 (0.51/0.58)	108/118 (0.55/0.6)	110/118 (0.56/0.6)
	5-3	Lowering Speed, Loaded/Unloaded, 2-Stg LFL	ft/min (m/s)	108/128 (0.55/0.65)			
	5-3-1	Lowering Speed, Loaded/Unloaded, 2-Stg FFL	ft/min (m/s)	98/118 (0.5/0.6)			
	5-3-2	Lowering Speed, Loaded/Unloaded, 3-Stg FFL	ft/min (m/s)	102/120 (0.52/0.61)			
	5-3-3	Lowering Speed, Loaded/Unloaded, 4-Stg FFL	ft/min (m/s)	77/89 (0.39/0.45)			
	5-5	Drawbar Pull, Loaded / Unloaded, 60 Minute Rating **	LBF (N)	1819/1945 (8090/8650)	1940/2070 (8630/9210)	3406/3556 (15150/15820)	3464/3561 (15410/15840)
	5-6	Maximum Drawbar Pull, Loaded / Unloaded, 5 Minute Rating ***	LBF (N)	3655/3811 (16260/16950)	3732/3887 (16600/17290)	4332/4496 (19270/20000)	5681/5778 (25270/25700)
	5-7	Gradeability, Loaded / Unloaded, 30 Minute Rating **** (10)	%	16/26	15/25	26/27	27/27
	5-8	Maximum Gradeability, Loaded / Unloaded, 5 Minute Rating **** (10)	%	24/27	24/27	29/27	39/27
	Gradeability, Loaded / Unloaded, 60 Minute Rating	%	12/19	12/21	22/27	23/27	
5-9	Acceleration Time, Loaded/Unloaded, 15m (9)	s	6.2/5.9	5.5/5.1	5.5/5.1	5.3/4.8	
5-10	Service Brake		Wet Disc - Oil Immersed				
ELECTRIC DRIVE	6-1	Drive Motor Rating S2 60 Min	Hp (kW)	2 x 11.8 (2x 8.8)		2 x 16.1 (2x 12)	
	6-2	Lift Motor Rating At S3 15%	Hp (kW)	26.9 (20.1)	26.9 (20.1)	29.1 (21.7)	28.8 (21.5)
	6-6	Energy Consumption According To DIN EN 16796 (11)	kWh/h	3.5	5.7	5.0	5.3
ADDITIONAL DATA	10-1	Operating Pressure For Attachments	bar	180			
	10-2	Oil Volume For Attachments (12)	gal/min (l/min)	10.6 (40)			
	10-3	Hydraulic Oil Tank, Capacity	gal (l)	5.6 (21.2)			
	10-7	Sound Pressure Level At The Driver's Seat (14) ANSI	dB (A)	71			
	10-8	Towing Coupling, Type DIN		Pin			

E55XN2 SPECIFICATIONS

				INTELMATCH		DURAMATCH		
GENERAL	1-1	Manufacturer				Hyster		
	1-2	Model Designation				E55XN2		
	1-2-1	Model				Standard		
	1-3	Drive: Electric (Battery Or Mains), Diesel, Gasoline, LPG				Electric (Battery)		
	1-4	Operator Type: Hand, Pedestrian, Standing, Seated, Order-Picker				Seated		
	1-5	Rated Capacity/Rated Load	Q	lb (kg)		5500 (2700)		
	1-6	Load Center Distance	c	in (mm)		24 (610)		
	1-8	Load Distance, Center Of Drive Axle To Fork	x	in (mm)		16.7 (425)		
	1-8-1	Battery Compartment Width		in (mm)		39.1 (992)		
	1-8-2	Battery Compartment Height (Without/With Battery Rollers)		in (mm)		23.9 / 23.4 (607 / 594)		
	1-8-3	Nominal Battery Compartment		in		33		
	1-8-4	Actual Battery Compartment		in (mm)		33.3 (847)		
	WEIGHT	1-9	Wheelbase (Short/Medium/Long)	y	in (mm)		54.8 (1392)	
2-1		Service Weight (1)		lb (kg)		11179 (5071)		
2-2		Axle Loading Loaded, Front/Rear (1)		lb (kg)		14016/2662 (6358/1207)		
WHEELS	2-3	Axle Loading Unloaded, Front/Rear (1)		lb (kg)		4433/6746 (2011/3060)		
	3-1	Tires, Front/Rear				Cushion, Smooth		
	3-2	Tire Size, Front		in		21 x 8 x 15		
	3-3	Tire Size, Rear		in		16 X 6 X 10.5		
	3-5	Number Of Wheels, Front/Rear (X = Driven)				2x / 2		
	3-6	Tread, Front, Standard / Wide	b10	in (mm)		35.7/41.1 (908/1043)		
	3-7	Tread, Rear, Standard	b11	in (mm)		36.9 (936)		
DIMENSIONS	4-1	Tilt Of Mast / Fork Carriage Forward / Backward	α / β	(o)		5 / 5		
	4-2	Height, Mast Lowered	h1	in (mm)		83.9 (2132)		
	4-3	Free Lift (2)	h2	in (mm)		3.9 (100)		
	4-4	Lift (2)	h3	in (mm)		126.8 (3220)		
	4-5	Height, Mast Extended (3)	h4	in (mm)		132.2 (3357)		
	4-7	Height Of Overhead Guard (4)	h6	in (mm)		88.5 (2248)		
	4-8	Seat Height Relating To Sip/Stand Height (5)	h7	in (mm)		48.5 (1233)		
	4-12	Coupling Height	h10	in (mm)		11 (279)		
	4-19	Overall Length	l1	in (mm)		128.1 (3255)		
	4-20	Length To Face Of Forks (6)	l2	in (mm)		86.1 (2188)		
	4-21	Overall Width, Standard / Wide	b1	in (mm)		44.1/49.1 (1120/1246)		
	4-22	Fork Dimensions DIN ISO 2331	s/e/l	in (mm)		1.6 x 3.9 x 42 (40 x 100 x 1067)		
	4-23	Fork Carriage ISO 2328, Class/Type A, B				II A		
	4-24	Fork Carriage Width (7)	b3	in (mm)		38.4 (977)		
	4-31	Ground Clearance, Loaded, Below Mast	m1	in (mm)		3.3 (84)		
	4-32	Ground Clearance, Center Of Wheelbase	m2	in (mm)		3.9 (100)		
	4-33	Load Dimensions B12 x L6 Crossways	b12/l6	in (mm)		47.2 x 39.4 (1200 x 1000)		
	4-34-1	Right Angle Stack For Pallets 40 in x 48 in (1000 x 1200 mm) (8)	Ast	in (mm)		137.2 (3484)		
	4-35	Turning Radius	Wa	in (mm)		71.3 (1812)		
	4-36	Internal Turning Radius	b13	in (mm)		8.2 (208)		
	4-41	90° intersecting aisle with pallet 48" long x 40" wide (1219 x 1016)	W2	in (mm)		75.9 (1927)		
	4-42	Step Height (From Ground To Running Board)		in (mm)		18.7 (475)		
	4-43	Step Height (Between Intermediate Steps Between Running Board And Floor)		in (mm)		11.4 (289)		
PERFORMANCE	8-1	Drive Control						
	8-1-1	Battery Voltage/Nominal Capacity K5		V / Ah	36	48	48	80
	5-1	Travel Speed, Loaded/Unloaded, Extended Shift Off (9)		mph (km/h)	9.7/10.6 (15.6/17.1)	11.3/11.0 (18.2/17.7)	12.4/12.1 (19.9/19.5)	12.5/12.2 (20.1/19.7)
	5-1-1	Travel Speed, Loaded/Unloaded, Extended Shift On (9)		mph (km/h)	9.8/10.6 (15.8/17.1)	11.3/11.0 (18.2/17.7)	12.4/12.1 (19.9/19.5)	12.5/12.2 (20.1/19.6)
	5-2	Lift Speed, Loaded/Unloaded, 2-Stg LFL		ft/min (m/s)	104/128 (0.53/0.65)	106/128 (0.54/0.65)	114/132 (0.58/0.67)	114/132 (0.58/0.67)
	5-2-1	Lift Speed, Loaded/Unloaded, 2-Stg FFL		ft/min (m/s)	96/118 (0.49/0.6)	98/118 (0.5/0.6)	104/122 (0.53/0.62)	104/122 (0.53/0.62)
	5-2-2	Lift Speed, Loaded/Unloaded, 3-Stg FFL		ft/min (m/s)	98/120 (0.5/0.61)	100/120 (0.51/0.61)	108/124 (0.55/0.63)	106/124 (0.54/0.63)
	5-2-3	Lift Speed, Loaded/Unloaded, 4-Stg FFL		ft/min (m/s)	77/114 (0.39/0.58)	94/114 (0.48/0.58)	102/118 (0.52/0.6)	108/118 (0.55/0.6)
	5-3	Lowering Speed, Loaded/Unloaded, 2-Stg LFL		ft/min (m/s)		108/128 (0.55/0.65)		
	5-3-1	Lowering Speed, Loaded/Unloaded, 2-Stg FFL		ft/min (m/s)		98/118 (0.5/0.6)		
	5-3-2	Lowering Speed, Loaded/Unloaded, 3-Stg FFL		ft/min (m/s)		102/120 (0.52/0.61)		
	5-3-3	Lowering Speed, Loaded/Unloaded, 4-Stg FFL		ft/min (m/s)		77/89 (0.39/0.45)		
	5-5	Drawbar Pull, Loaded / Unloaded, 60 Minute Rating **		LBF (N)	1801/1938 (8010/8620)	1924/2064 (8560/9180)	3390/3550 (15080/15790)	3449/3554 (15340/15810)
5-6	Maximum Drawbar Pull, Loaded / Unloaded, 5 Minute Rating ***		LBF (N)	4332/4496 (19270/20000)	3714/3880 (16520/17260)	4316/4492 (19200/19980)	5665/5771 (25200/25670)	
5-7	Gradeability, Loaded / Unloaded, 30 Minute Rating **** (10)		%	15/25	14/24	24/25	25/25	
5-8	Maximum Gradeability, Loaded / Unloaded, 5 Minute Rating **** (10)		%	23/25	23/25	27/25	36/25	
	Gradeability, Loaded / Unloaded, 60 Minute Rating		%	12/20	12/20	21/25	21/25	
5-9	Acceleration Time, Loaded/Unloaded, 15m (9)		s	6.3/5.8	5.6/5.1	5.6/5.1	5.3/4.9	
5-10	Service Brake				Wet Disc - Oil Immersed			
ELECTRIC DRIVE	6-1	Drive Motor Rating S2 60 Min		Hp (kW)	2 x 11.8 (2x 8.8)		2 x 16.1 (2x 12)	
	6-2	Lift Motor Rating At S3 15%		Hp (kW)	26.9 (20.1)	26.9 (20.1)	29.1 (21.7)	28.8 (21.5)
	6-6	Energy Consumption According To DIN EN 16796 (11)		kWh/h	3.9	6.1	5.5	5.8
ADDITIONAL DATA	10-1	Operating Pressure For Attachments		bar	180			
	10-2	Oil Volume For Attachments (12)		gal/min (l/min)	10.6 (40)			
	10-3	Hydraulic Oil Tank, Capacity		gal (l)	5.6 (21.2)			
	10-7	Sound Pressure Level At The Driver's Seat (14) ANSI		dB [A]	71			
10-8	Towing Coupling, Type DIN			Pin				

E60XN2 SPECIFICATIONS

				INTELMATCH	DURAMATCH		
GENERAL	1-1	Manufacturer		Hyster			
	1-2	Model Designation		E60XN2			
	1-2-1	Model		Standard			
	1-3	Drive: Electric (Battery Or Mains), Diesel, Gasoline, LPG		Electric (Battery)			
	1-4	Operator Type: Hand, Pedestrian, Standing, Seated, Order-Picker		Seated			
	1-5	Rated Capacity/Rated Load	Q	lb (kg)	6000 (3000)		
	1-6	Load Center Distance	c	in (mm)	24 (610)		
	1-8	Load Distance, Center Of Drive Axle To Fork	x	in (mm)	17.1 (435)		
		Battery Compartment Width		in (mm)	39.1 (992)		
		Battery Compartment Height (Without/With Battery Rollers)		in (mm)	23.9 / 23.4 (607 / 594)		
	Nominal Battery Compartment		in	33			
	Actual Battery Compartment		in (mm)	33.3 (847)			
WEIGHT	1-9	Wheelbase (Short/Medium/Long)	y	in (mm)	54.8 (1392)		
	2-1	Service Weight (1)		lb (kg)	11815 (5359)		
	2-2	Axle Loading Loaded, Front/Rear (1)		lb (kg)	14920/2895 (6768/1313)		
WHEELS	2-3	Axle Loading Unloaded, Front/Rear (1)		lb (kg)	4421/7394 (2005/3354)		
	3-1	Tires, Front/Rear			Cushion, Smooth		
	3-2	Tire Size, Front		in	21 x 8 x 15		
	3-3	Tire Size, Rear		in	16 x 6 x 10.5		
	3-5	Number Of Wheels, Front/Rear (X = Driven)			2x / 2		
	3-6	Tread, Front, Standard / Wide	b10	in (mm)	35.7/41.1 (908/1043)		
	3-7	Tread, Rear, Standard	b11	in (mm)	36.9 (936)		
DIMENSIONS	4-1	Tilt Of Mast / Fork Carriage Forward / Backward	α / β	($^{\circ}$)	5 / 5		
	4-2	Height, Mast Lowered	h1	in (mm)	83.9 (2132)		
	4-3	Free Lift (2)	h2	in (mm)	3.9 (100)		
	4-4	Lift (2)	h3	in (mm)	119.2 (3028)		
	4-5	Height, Mast Extended (3)	h4	in (mm)	124.0 (3150)		
	4-7	Height Of Overhead Guard (4)	h6	in (mm)	88.5 (2248)		
	4-8	Seat Height Relating To Sip/Stand Height (5)	h7	in (mm)	48.5 (1233)		
	4-12	Coupling Height	h10	in (mm)	11 (279)		
	4-19	Overall Length	l1	in (mm)	128.7 (3269)		
	4-20	Length To Face Of Forks (6)	l2	in (mm)	86.7 (2202)		
	4-21	Overall Width, Standard / Wide	b1	in (mm)	44.1/49.1 (1120/1246)		
	4-22	Fork Dimensions DIN ISO 2331	s/e/l	in (mm)	2 x 4.9 x 42 (50 x 125 x 1067)		
	4-23	Fork Carriage ISO 2328, Class/Type A, B			III A		
	4-24	Fork Carriage Width (7)	b3	in (mm)	38.4 (977)		
	4-31	Ground Clearance, Loaded, Below Mast	m1	in (mm)	3.3 (84)		
	4-32	Ground Clearance, Center Of Wheelbase	m2	in (mm)	3.9 (99)		
	4-33	Load Dimensions B12 x L6 Crossways	b12/l6	in (mm)	47.2 x 39.4 (1200 x 1000)		
	4-34-1	Right Angle Stack for pallets 48 in Long x 40 in wide (1219 x 1016) (8)	Ast	in (mm)	138.7 (3524)		
	4-35	Turning Radius	Wa	in (mm)	72.5 (1842)		
	4-36	Internal Turning Radius	b13	in (mm)	52.4 (1332)		
	4-41	90° intersecting aisle with pallet 48" long x 40" wide (1219 x 1016)	W2	in (mm)	76.4 (1940)		
	4-42	Step Height (From Ground To Running Board)		in (mm)	18.7 (475)		
	4-43	Step Height (Between Intermediate Steps Between Running Board And Floor)		in (mm)	11.4 (289)		
PERFORMANCE	8-1	Drive Control					
		Battery Voltage/Nominal Capacity K5	V / Ah	36	48	48	80
	5-1	Travel Speed, Loaded/Unloaded, Extended Shift Off (9)	mph (km/h)	9.7/10.6 (15.6/17.1)	11.3/11.0 (18.2/17.7)	12.4/12.1 (19.9/19.5)	12.5/12.2 (20.1/19.7)
	5-1-1	Travel Speed, Loaded/Unloaded, Extended Shift On (9)	mph (km/h)	9.8/10.6 (15.8/17.1)	11.3/11.0 (18.2/17.7)	12.4/12.1 (19.9/19.5)	12.5/12.2 (20.1/19.6)
	5-2	Lift Speed, Loaded/Unloaded, 2-Stg LFL	ft/min (m/s)	87/122 (0.44/0.62)	89/122 (0.45/0.62)	94/126 (0.48/0.64)	94/126 (0.48/0.64)
	5-2-1	Lift Speed, Loaded/Unloaded, 2-Stg FFL	ft/min (m/s)	83/114 (0.42/0.58)	83/114 (0.42/0.58)	91/118 (0.46/0.6)	89/118 (0.45/0.6)
	5-2-2	Lift Speed, Loaded/Unloaded, 3-Stg FFL	ft/min (m/s)	83/118 (0.42/0.6)	85/118 (0.43/0.6)	91/122 (0.46/0.62)	91/122 (0.46/0.62)
	5-2-3	Lift Speed, Loaded/Unloaded, 4-Stg FFL	ft/min (m/s)	77/114 (0.39/0.58)	79/114 (0.4/0.58)	85/118 (0.43/0.6)	83/118 (0.42/0.6)
	5-3	Lowering Speed, Loaded/Unloaded, 2-Stg LFL	ft/min (m/s)		94/102 (0.48/0.52)		
	5-3-1	Lowering Speed, Loaded/Unloaded, 2-Stg FFL	ft/min (m/s)		89/96 (0.45/0.49)		
	5-3-2	Lowering Speed, Loaded/Unloaded, 3-Stg FFL	ft/min (m/s)		91/98 (0.46/0.5)		
	5-3-3	Lowering Speed, Loaded/Unloaded, 4-Stg FFL	ft/min (m/s)		77/89 (0.39/0.45)		
	5-5	Drawbar Pull, Loaded / Unloaded, 60 Minute Rating **	LBF (N)	1780/1927 (7920/8570)	1904/2053 (8470/9130)	3368/3538 (14980/15740)	3426/3543 (15240/15760)
	5-6	Maximum Drawbar Pull, Loaded / Unloaded, 5 Minute Rating ***	LBF (N)	3617/3793 (16090/16870)	3694/3869 (16430/17210)	4294/4478 (19100/19920)	5643/5760 (25100/25620)
	5-7	Gradeability, Loaded / Unloaded, 30 Minute Rating **** (10)	%	14/23	13/22	22/25	23/25
5-8	Maximum Gradeability, Loaded / Unloaded, 5 Minute Rating **** (10)	%	21/25	21/25	25/25	33/25	
	Gradeability, Loaded / Unloaded, 60 Minute Rating	%	10/17	11/18	19/25	19/25	
5-9	Acceleration Time, Loaded/Unloaded, 15m (9)	s	6.4/5.9	5.7/5.2	5.6/5.2	5.4/4.9	
5-10	Service Brake			Wet Disc - Oil Immersed			
ELECTRIC DRIVE	6-1	Drive Motor Rating S2 60 Min	Hp (kW)	2 x 11.8 (2x 8.8)		2 x 16.1 (2x 12)	
	6-2	Lift Motor Rating At S3 15%	Hp (kW)	26.9 (20.1)	26.9 (20.1)	29.1 (21.7)	28.8 (21.5)
	6-6	Energy Consumption According To DIN EN 16796 (11)	kWh/h	4.4	6.6	6.1	6.3
ADDITIONAL DATA	10-1	Operating Pressure For Attachments	bar	180			
	10-2	Oil Volume For Attachments (12)	gal/min (l/min)	10.6 (40)			
	10-3	Hydraulic Oil Tank, Capacity	gal (l)	5.6 (21.2)			
	10-7	Sound Pressure Level At The Driver's Seat (14) ANSI	dB [A]	71			
10-8	Towing Coupling, Type DIN		Pin				

E65XN2 SPECIFICATIONS

			INTELMATCH				DURAMATCH	
			36	48	48	80		
GENERAL	1-1	Manufacturer	Hyster					
	1-2	Model Designation	E65XN2					
	1-2-1	Model	Standard					
	1-3	Drive: Electric (Battery Or Mains), Diesel, Gasoline, LPG	Electric (Battery)					
	1-4	Operator Type: Hand, Pedestrian, Standing, Seated, Order-Picker	Seated					
	1-5	Rated Capacity/Rated Load	Q	lb (kg)	6500 (3200)			
	1-6	Load Center Distance	c	in (mm)	24 (610)			
	1-8	Load Distance, Center Of Drive Axle To Fork	x	in (mm)	17.1 (435)			
		Battery Compartment Width		in (mm)	39.1 (992)			
		Battery Compartment Height (Without/With Battery Rollers)		in (mm)	23.9 / 23.4 (607 / 594)			
	Nominal Battery Compartment		in	36		40		
	Actual Battery Compartment		in (mm)	36.7 (933)		40 (1015)		
WEIGHT	1-9	Wheelbase (Short/Medium/Long)	y	in (mm)	58.2 (1478)		61.4 (1560)	
	2-1	Service Weight (1)		lb (kg)	12215 (5541)		11946 (5419)	
	2-2	Axle Loading Loaded, Front/Rear (1)		lb (kg)	15861/2854 (7194/1295)		15817/2628 (7174/1192)	
WHEELS	2-3	Axle Loading Unloaded, Front/Rear (1)		lb (kg)	4770/7445 (2164/3377)		4968/6978 (2253/3165)	
	3-1	Tires, Front/Rear			Cushion, Smooth			
	3-2	Tire Size, Front		in	21 x 9 x 15			
	3-3	Tire Size, Rear		in	16 x 7 x 10.5			
	3-5	Number Of Wheels, Front/Rear (X = Driven)			2x / 2			
	3-6	Tread, Front, Standard / Wide	b10	in (mm)	36.8/40 (934/1016)			
	3-7	Tread, Rear, Standard	b11	in (mm)	37.3 (947)			
DIMENSIONS	4-1	Tilt Of Mast / Fork Carriage Forward / Backward	α / β	($^{\circ}$)	5 / 5			
	4-2	Height, Mast Lowered	h1	in (mm)	83.9 (2132)			
	4-3	Free Lift (2)	h2	in (mm)	3.9 (100)			
	4-4	Lift (2)	h3	in (mm)	119.2 (3028)			
	4-5	Height, Mast Extended (3)	h4	in (mm)	124.0 (3150)			
	4-7	Height Of Overhead Guard (4)	h6	in (mm)	88.5 (2248)			
	4-8	Seat Height Relating To SIP/Stand Height (5)	h7	in (mm)	48.5 (1233)			
	4-12	Coupling Height	h10	in (mm)	11 (279)			
	4-19	Overall Length	l1	in (mm)	132.1 (3355)		134.8 (3423)	
	4-20	Length To Face Of Forks (6)	l2	in (mm)	90.1 (2288)		92.8 (2356)	
	4-21	Overall Width, Standard / Wide	b1	in (mm)	46.1/49 (1172/1245)			
	4-22	Fork Dimensions DIN ISO 2331	s/e/l	in (mm)	2 x 4.9 x 42 (50 x 125 x 1067)			
	4-23	Fork Carriage ISO 2328, Class/Type A, B			III A			
	4-24	Fork Carriage Width (7)	b3	in (mm)	38.4 (977)			
	4-31	Ground Clearance, Loaded, Below Mast	m1	in (mm)	3.3 (84)			
	4-32	Ground Clearance, Center Of Wheelbase	m2	in (mm)	3.9 (98)		3.9 (99)	
	4-33	Load Dimensions B12 x L6 Crossways	b12/l6	in (mm)	47.2 x 39.4 (1200 x 1000)			
	4-34-1	Right Angle Stack for pallets 48 in Long x 40 in wide (1219 x 1016) (8)	Ast	in (mm)	142 (3607)		143.9 (3655)	
	4-35	Turning Radius	Wa	in (mm)	75.9 (1927)		77.8 (1977)	
	4-36	Internal Turning Radius	b13	in (mm)	8.7 (221)		9.2 (233)	
	4-41	90° intersecting aisle with pallet 48" long x 40" wide (1219 x 1016)	W2	in (mm)	77.1 (1958)		78 (1980)	
	4-42	Step Height (From Ground To Running Board)		in (mm)	18.7 (475)		18.7 (475)	
	4-43	Step Height (Between Intermediate Steps Between Running Board And Floor)		in (mm)	11.4 (289)		11.4 (289)	
PERFORMANCE	8-1	Drive Control			INTELMATCH			
		Battery Voltage/Nominal Capacity K5	V / Ah		36	48	48	80
	5-1	Travel Speed, Loaded/Unloaded, Extended Shift Off (9)	mph (km/h)		9.6/10.2 (15.5/16.4)	11.3/11.0 (18.2/17.7)	12.4/12.1 (19.9/19.5)	12.5/12.2 (20.1/19.7)
	5-1-1	Travel Speed, Loaded/Unloaded, Extended Shift On (9)	mph (km/h)		8.5/9.5 (13.7/15.2)	11.3/11.0 (18.2/17.7)	12.4/12.1 (19.9/19.5)	12.5/12.2 (20.1/19.6)
	5-2	Lift Speed, Loaded/Unloaded, 2-Stg LFL	ft/min (m/s)		83/122 (0.42/0.62)	85/122 (0.43/0.62)	91/126 (0.46/0.64)	91/126 (0.46/0.64)
	5-2-1	Lift Speed, Loaded/Unloaded, 2-Stg FFL	ft/min (m/s)		77/114 (0.39/0.58)	79/114 (0.4/0.58)	85/118 (0.43/0.6)	85/118 (0.43/0.6)
	5-2-2	Lift Speed, Loaded/Unloaded, 3-Stg FFL	ft/min (m/s)		79/118 (0.4/0.6)	81/118 (0.41/0.6)	87/122 (0.44/0.62)	87/122 (0.44/0.62)
	5-2-3	Lift Speed, Loaded/Unloaded, 4-Stg FFL	ft/min (m/s)		N/A			
	5-3	Lowering Speed, Loaded/Unloaded, 2-Stg LFL	ft/min (m/s)		94/102 (0.48/0.52)			
	5-3-1	Lowering Speed, Loaded/Unloaded, 2-Stg FFL	ft/min (m/s)		89/96 (0.45/0.49)			
	5-3-2	Lowering Speed, Loaded/Unloaded, 3-Stg FFL	ft/min (m/s)		91/98 (0.46/0.5)			
	5-3-3	Lowering Speed, Loaded/Unloaded, 4-Stg FFL	ft/min (m/s)		N/A			
	5-5	Drawbar Pull, Loaded / Unloaded, 60 Minute Rating **	LBF (N)		1765/1922 (7850/8550)	1888/2048 (8400/9110)	3354/3534 (14920/15720)	3413/3538 (15180/15740)
	5-6	Maximum Drawbar Pull, Loaded / Unloaded, 5 Minute Rating ***	LBF (N)		3604/3788 (16030/16850)	3678/3864 (16360/17190)	4280/4474 (19040/19900)	5629/5753 (25040/25590)
	5-7	Gradeability, Loaded / Unloaded, 30 Minute Rating **** (10)	%		13/23	12/22	21/26	22/26
5-8	Maximum Gradeability, Loaded / Unloaded, 5 Minute Rating **** (10)	%		20/26	20/26	23/26	32/26	
	Gradeability, Loaded / Unloaded, 60 Minute Rating	%		9/17	10/18	18/26	19/26	
5-9	Acceleration Time, Loaded/Unloaded, 15m (9)	s		6.5/5.9	5.7/5.2	5.7/5.2	5.4/4.9	
5-10	Service Brake			Wet Disc - Oil Immersed				
ELECTRIC DRIVE	6-1	Drive Motor Rating S2 60 Min	Hp (kW)		2 x 11.8 (2x 8.8)		2 x 16.1 (2x 12)	
	6-2	Lift Motor Rating At S3 15%	Hp (kW)		26.9 (20.1)		29.1 (21.7)	
	6-6	Energy Consumption According To DIN EN 16796 (11)	kWh/h		4.7	6.9	6.5	6.7
ADDITIONAL DATA	10-1	Operating Pressure For Attachments	bar		180			
	10-2	Oil Volume For Attachments (12)	gal/min (l/min)		10.6 (40)			
	10-3	Hydraulic Oil Tank, Capacity	gal (l)		5.6 (21.2)			
	10-7	Sound Pressure Level At The Driver's Seat (14) ANSI	dB [A]		71			
10-8	Towing Coupling, Type DIN			Pin				

E70XN2 SPECIFICATIONS

				INTELMATCH		DURAMATCH		
GENERAL	1-1	Manufacturer		Hyster				
	1-2	Model Designation		E70XN2				
	1-2-1	Model		Standard				
	1-3	Drive: Electric (Battery Or Mains), Diesel, Gasoline, LPG		Electric (Battery)				
	1-4	Operator Type: Hand, Pedestrian, Standing, Seated, Order-Picker		Seated				
	1-5	Rated Capacity/Rated Load	Q	lb (kg)	7000 (3500)			
	1-6	Load Center Distance	c	in (mm)	24 (610)			
	1-8	Load Distance, Center Of Drive Axle To Fork	x	in (mm)	17.1 (435)			
		Battery Compartment Width		in (mm)	39.1 (992)			
		Battery Compartment Height (Without/With Battery Rollers)		in (mm)	23.9 / 23.4 (607 / 594)			
	Nominal Battery Compartment		in	40				
	Actual Battery Compartment		in (mm)	40 (1015)				
WEIGHT	1-9	Wheelbase (Short/Medium/Long)	y	in (mm)	61.4 (1560)			
	2-1	Service Weight (1)		lb (kg)	12552 (5693)			
	2-2	Axle Loading Loaded, Front/Rear (1)		lb (kg)	16648/2904 (7551/1317)			
	2-3	Axle Loading Unloaded, Front/Rear (1)		lb (kg)	4964/7588 (2252/3442)			
WHEELS	3-1	Tires, Front/Rear		Cushion, Smooth				
	3-2	Tire Size, Front		in	21 x 9 x 15			
	3-3	Tire Size, Rear		in	16 x 7 x 10.5			
	3-5	Number Of Wheels, Front/Rear (X = Driven)		2x / 2				
	3-6	Tread, Front, Standard / Wide	b10	in (mm)	36.8/40 (934/1016)			
	3-7	Tread, Rear, Standard	b11	in (mm)	37.3 (947)			
		4-1	Tilt Of Mast / Fork Carriage Forward / Backward	α / β	($^{\circ}$)	5 / 5		
DIMENSIONS	4-2	Height, Mast Lowered	h1	in (mm)	83.9 (2132)			
	4-3	Free Lift (2)	h2	in (mm)	3.9 (100)			
	4-4	Lift (2)	h3	in (mm)	119.2 (3028)			
	4-5	Height, Mast Extended (3)	h4	in (mm)	124.0 (3150)			
	4-7	Height Of Overhead Guard (4)	h6	in (mm)	88.5 (2248)			
	4-8	Seat Height Relating To Sip/Stand Height (5)	h7	in (mm)	48.5 (1233)			
	4-12	Coupling Height	h10	in (mm)	11 (279)			
	4-19	Overall Length	l1	in (mm)	135.3 (3437)			
	4-20	Length To Face Of Forks (6)	l2	in (mm)	93.3 (2370)			
	4-21	Overall Width, Standard / Wide	b1	in (mm)	46.1/49 (1172/1245)			
	4-22	Fork Dimensions DIN ISO 2331	s/e/l	in (mm)	2 x 4.9 x 42 (50 x 125 x 1067)			
	4-23	Fork Carriage ISO 2328, Class/Type A, B		III A				
	4-24	Fork Carriage Width (7)	b3	in (mm)	38.4 (977)			
	4-31	Ground Clearance, Loaded, Below Mast	m1	in (mm)	3.3 (84)			
	4-32	Ground Clearance, Center Of Wheelbase	m2	in (mm)	3.9 (99)			
	4-33	Load Dimensions B12 x L6 Crossways	b12/l6	in (mm)	47.2 x 39.4 (1200 x 1000)			
	4-34-1	Right Angle Stack for pallets 48 in Long x 40 in wide (1219 x 1016) (8)	Ast	in (mm)	145.1 (3686)			
	4-35	Turning Radius	Wa	in (mm)	79.1 (2008)			
	4-36	Internal Turning Radius	b13	in (mm)	9.2 (233)			
	4-41	90° intersecting aisle with pallet 48" long x 40" wide (1219 x 1016)	W2	in (mm)	78.5 (1994)			
	4-42	Step Height (From Ground To Running Board)		in (mm)	18.7 (475)			
	4-43	Step Height (Between Intermediate Steps Between Running Board And Floor)		in (mm)	11.4 (289)			
	PERFORMANCE	8-1	Drive Control					
		Battery Voltage/Nominal Capacity K5	V / Ah	36	48	48	80	
5-1		Travel Speed, Loaded/Unloaded, Extended Shift Off (9)	mph (km/h)	7.9/9.3 (12.7/15.0)	10.9/11.0 (17.6/17.7)	12.4/12.1 (19.9/19.5)	12.4/12.2 (20.0/19.7)	
5-1-1		Travel Speed, Loaded/Unloaded, Extended Shift On (9)	mph (km/h)	8.2/9.3 (13.1/15.0)	10.9/11.0 (17.6/17.7)	12.4/12.1 (19.9/19.5)	12.4/12.2 (20.0/19.6)	
5-2		Lift Speed, Loaded/Unloaded, 2-Stg LFL	ft/min (m/s)	79/122 (0.4/0.62)	81/122 (0.41/0.62)	87/126 (0.44/0.64)	87/126 (0.44/0.64)	
5-2-1		Lift Speed, Loaded/Unloaded, 2-Stg FFL	ft/min (m/s)	75/114 (0.38/0.58)	75/114 (0.38/0.58)	81/118 (0.41/0.6)	81/118 (0.41/0.6)	
5-2-2		Lift Speed, Loaded/Unloaded, 3-Stg FFL	ft/min (m/s)	77/118 (0.39/0.6)	77/118 (0.39/0.6)	83/122 (0.42/0.62)	83/122 (0.42/0.62)	
5-2-3		Lift Speed, Loaded/Unloaded, 4-Stg FFL	ft/min (m/s)	N/A				
5-3		Lowering Speed, Loaded/Unloaded, 2-Stg LFL	ft/min (m/s)	94/102 (0.48/0.52)				
5-3-1		Lowering Speed, Loaded/Unloaded, 2-Stg FFL	ft/min (m/s)	89/96 (0.45/0.49)				
5-3-2		Lowering Speed, Loaded/Unloaded, 3-Stg FFL	ft/min (m/s)	91/98 (0.46/0.5)				
5-3-3		Lowering Speed, Loaded/Unloaded, 4-Stg FFL	ft/min (m/s)	N/A				
5-5		Drawbar Pull, Loaded / Unloaded, 60 Minute Rating **	LBF (N)	1747/1913 (7770/8510)	1870/2039 (8320/9070)	3336/3525 (14840/15680)	3392/3530 (15090/15700)	
5-6		Maximum Drawbar Pull, Loaded / Unloaded, 5 Minute Rating ***	LBF (N)	3586/3779 (15950/16810)	3660/3855 (16280/17150)	4262/4465 (18960/19860)	5609/5744 (24950/25550)	
5-7		Gradeability, Loaded / Unloaded, 30 Minute Rating **** (10)	%	12/22	12/21	20/24	21/24	
5-8	Maximum Gradeability, Loaded / Unloaded, 5 Minute Rating **** (10)	%	18/24	19/24	22/24	30/24		
	Gradeability, Loaded / Unloaded, 60 Minute Rating	%	9/16	9/17	17/24	17/24		
5-9	Acceleration Time, Loaded/Unloaded, 15m (9)	s	6.7/6.0	6.1/5.6	5.8/5.2	5.6/5.1		
5-10	Service Brake		Wet Disc - Oil Immersed					
ELECTRIC DRIVE	6-1	Drive Motor Rating S2 60 Min	Hp (kW)	2 x 11.8 (2x 8.8)		2 x 16.1 (2x 12)		
	6-2	Lift Motor Rating At S3 15%	Hp (kW)	26.9 (20.1)	26.9 (20.1)	29.1 (21.7)	28.8 (21.5)	
	6-6	Energy Consumption According To DIN EN 16796 (11)	kWh/h	5.2	7.3	7.1	7.2	
ADDITIONAL DATA	10-1	Operating Pressure For Attachments	bar	180				
	10-2	Oil Volume For Attachments (12)	gal/min (l/min)	10.6 (40)				
	10-3	Hydraulic Oil Tank, Capacity	gal (l)	5.6 (21.2)				
	10-7	Sound Pressure Level At The Driver's Seat (14) ANSI	dB [A]	71				
10-8	Towing Coupling, Type DIN		Pin					

E45-70XN2 DIMENSIONS

NOTES

- (1) Max. battery
- (2) Bottom of forks
- (3) Add 25.2" (641 mm) with class II load backrest. Add 22.3" (568 mm) with class III load backrest.
- (4) h6 subject to +/- 5 mm tolerance.
- (5) Full suspension in compressed position specified. Add 1.5" (40 mm) for nominal position.
- (6) With sideshift carriage add 1" (25 mm) for Class 2 carriage, 1.1" (28 mm) for Class 3 carriage
- (7) Add 1.5" (39 mm) with load backrest.
- (8) Stacking aisle width (lines 4.34.1) is based on the calculation as shown on illustration. Recommended addition of 200 mm to the total clearance (dimension a) for extra operating margin at the rear of the truck.
- (9) HIP Performance settings
- (10) Gradeability figures (lines 5.7 & 5.8) are provided for comparison of tractive performance, but are not intended to endorse the operation of the vehicle on the stated inclines. Follow instructions in the operating manual regarding operation on inclines.
- (11) eLo Performance settings
- (12) Maximum flow set through dash display.
- (13) LPAZ, measured according to the test cycles and based on the weighting values contained in ITSDF B56.11.5 2023

* Standard / Wide tread

** 60 minute rating

*** 5 minute rating

**** 30 minute rating

Spec sheet truck based on:- 128.3" (3260mm) E45-55XN2 / 120.8" (3078mm) (E60-70XN2) TOF 2 stage LFL Mast with standard carriage, 40" mm forks.

CERTIFICATION: Hyster lift trucks meet the design and construction requirements of B56.1-1969, per OSHA Section 1910.178(a)(2), and also comply with the B56.1 revision in effect at time of manufacture. Certification of compliance with the applicable ANSI standards appears on the lift truck. Performance specifications are for a truck equipped as described under Standard Equipment on this technical guide. Performance specifications are affected by the condition of the vehicle and how it is equipped, as well as by the nature, condition of the operating area, proper service and maintenance of the vehicle. If these specifications are critical, the proposed application should be discussed with your dealer.

E45-70XN2 BATTERY AND COMPARTMENT SPECIFICATIONS

BATTERY AND COMPARTMENT SPECIFICATIONS									
BATTERY COMPARTMENT	WIDTH	LENGTH	HEIGHT	"X"	"Y"	"Z"	VOLTS	WEIGHT	
								MIN	MAX
	IN (MM)							LB (KG)	
27"	39.1 (992)	23.9 (700)	23.9 (607)	38.7 (983)	27.2 (691)	23.5 (597)	36	1050	1500
							48		
							80		
30"	39.1 (992)	30.9 (786)	23.9 (607)	38.7 (983)	30.6 (777)	23.5 (597)	36	1150	1600
							48		
							80		
33"	39.1 (992)	33.3 (847)	23.9 (607)	38.7 (983)	33 (838)	23.5 (597)	36	1320	1770
							48		
							80		
36"	39.1 (992)	36.7 (933)	23.9 (607)	38.7 (983)	36.4 (924)	23.5 (597)	36	1410	1860
							48		
							80		
40"	39.1 (992)	40 (1015)	23.9 (607)	38.7 (983)	39.6 (1006)	23.5 (597)	36	1550	2000
							48		
							80		

E45-70XN2 MAST DIMENSIONS

CLASS 2 MAST																			
CUSHION, SMOOTH TIRES													BATTERY COMPARTMENT						
MAXIMUM FORK LIFT (MM)	MAXIMUM FORK LIFT (IN)	LOWERED HEIGHT (MM)	LOWERED HEIGHT (IN)	EXTENDED HEIGHT WITHOUT LBR (MM)	EXTENDED HEIGHT WITHOUT LBR (IN)	EXTENDED HEIGHT WITH 1220 LBR (MM)	EXTENDED HEIGHT WITH 48 LBR (IN)	FREE LIFT HEIGHT BOTTOM OF FORKS (MM)	FREE LIFT HEIGHT BOTTOM OF FORKS (IN)	FREE LIFT HEIGHT TOP OF FORKS (MM)	FREE LIFT HEIGHT TOP OF FORKS (IN)	BACK TILT (°)	27	30	33	27	30	33	33
													E45XN2 CAPACITIES (LBS) @ 24 IN LOAD CENTER	E45XN2 CAPACITIES (LBS) @ 24 IN LOAD CENTER	E45XN2 CAPACITIES (LBS) @ 24 IN LOAD CENTER	E50XN2 CAPACITIES (LBS) @ 24 IN LOAD CENTER	E50XN2 CAPACITIES (LBS) @ 24 IN LOAD CENTER	E50XN2 CAPACITIES (LBS) @ 24 IN LOAD CENTER	E55XN2 CAPACITIES (LBS) @ 24 IN LOAD CENTER
2-STAGE LIMITED FREE LIFT																			
3260	128	2132	84	3827	151	4480	176	100	4	140	6	5	4500	4500	4500	5000	5000	5000	5500
3360	132	2182	86	3927	155	4580	180	100	4	140	6	5	4500	4500	4500	5000	5000	5000	5500
3460	136	2232	88	4027	159	4680	184	100	4	140	6	5	4500	4500	4500	5000	5000	5000	5500
3660	144	2332	92	4227	166	4880	192	100	4	140	6	5	4500	4500	4500	5000	5000	5000	5500
3760	148	2382	94	4327	170	4980	196	100	4	140	6	5	4500	4500	4500	5000	5000	5000	5500
3900	154	2532	100	4467	176	5120	202	100	4	140	6	5	4500	4500	4500	5000	5000	5000	5500
4200	165	2682	106	4767	188	5420	213	100	4	140	6	5	4500	4500	4500	5000	5000	5000	5500
4500	177	2832	111	5067	199	5720	225	100	4	140	6	5	4450	4450	4450	4950	4950	4950	5450
4800	189	2982	117	5367	211	6020	237	100	4	140	6	5	4350	4350	4350	4850	4850	4850	5350
5000	197	3182	125	5667	219	6220	245	100	4	140	6	5	4300	4300	4300	4800	4800	4800	5300
5500	217	3432	135	6067	239	6720	265	100	4	140	6	5	4150	4150	4150	4650	4600	4600	5100
6100	240	3832	151	6667	262	7320	288	100	4	140	6	5	3950	3950	3950	4100	4250	4250	4250
2-STAGE FULL FREE LIFT																			
2990	118	1982	78	3551	140	4210	166	722	28	762	30	5	4500	4500	4500	5000	5000	5000	5500
3240	128	2082	82	3801	150	4460	176	822	32	862	34	5	4500	4500	4500	5000	5000	5000	5500
3340	131	2132	84	3901	154	4560	180	872	34	912	36	5	4500	4500	4500	5000	5000	5000	5500
3440	135	2182	86	4001	158	4660	183	922	36	962	38	5	4500	4500	4500	5000	5000	5000	5500
3540	139	2232	88	4101	161	4760	187	972	38	1012	40	5	4500	4500	4500	5000	5000	5000	5500
3640	143	2282	90	4201	165	4860	191	1022	40	1062	42	5	4500	4500	4500	5000	5000	5000	5500
3740	147	2332	92	4301	169	4960	195	1072	42	1112	44	5	4500	4500	4500	5000	5000	5000	5500
3840	151	2382	94	4401	173	5060	199	1122	44	1162	46	5	4500	4500	4500	5000	5000	5000	5500
4060	160	2532	100	4621	182	5280	208	1272	50	1312	52	5	4500	4500	4500	5000	5000	5000	5500
4560	180	2782	110	5121	202	5780	228	1522	60	1562	61	5	4400	4400	4400	4900	4900	4900	5400
4960	195	2982	117	5521	217	6180	243	1722	68	1762	69	5	4300	4300	4300	4800	4800	4800	5300
5560	219	3332	131	6121	241	6780	267	2072	82	2112	83	5	4100	4100	4150	4600	4600	4600	5050
3-STAGE FULL FREE LIFT																			
4400	173	1982	78	4952	195	5620	221	722	28	762	30	5	4500	4500	4500	5000	5000	5000	5500
4650	183	2032	80	5202	205	5870	231	772	30	812	32	5	4400	4400	4400	4900	4900	4900	5400
4800	189	2082	82	5352	211	6020	237	822	32	862	34	5	4350	4350	4350	4850	4850	4850	5350
4950	195	2132	84	5502	217	6170	243	872	34	912	36	5	4300	4300	4350	4800	4800	4800	5300
5100	201	2232	88	5652	223	6320	249	922	38	1012	40	5	4300	4250	4300	4750	4750	4750	5250
5250	207	2282	90	5802	228	6470	255	1022	40	1062	42	5	4250	4200	4250	4700	4700	4700	5200
5550	219	2382	94	6102	240	6770	267	1122	44	1162	46	5	4150	4100	4150	4600	4600	4600	5100
5700	224	2482	98	6252	246	6920	272	1222	48	1262	50	5	4100	4050	4100	4400	4550	4550	5050
6150	242	2632	104	6702	264	7370	290	1372	54	1412	56	5	3700	3900	3950	3750	4100	4350	4850
6450	254	2782	110	7002	276	7670	302	1522	60	1562	61	5	3350	3650	3700	3350	3700	4050	4250
6900	272	2982	117	7452	293	8120	320	1722	68	1762	69	5	2850	3200	3250	2800	3200	3550	3650
7500	295	3232	127	8052	317	8720	343	1972	78	2012	79	5	2200	2550	2700	2050	2500	2700	2700
8100	319	3482	137	8652	341	9320	367	2222	87	2262	89	5	1650	2050	2050	1400	1900	2050	2050
4-STAGE FULL FREE LIFT																			
4940	194	1982	78	5492	216	6170	243	712	28	752	30	4	4400	4350	4500	4800	4850	4800	5000
5240	206	1982	78	5792	228	6470	255	712	28	752	30	4	4300	4300	4450	4400	4600	4750	5000
5540	218	1982	78	6092	240	6770	267	712	28	752	30	4	3950	4100	4150	4050	4250	4450	5000
5790	228	2032	80	6346	250	7024	277	762	30	802	32	4	3700	3850	3900	3750	4000	4200	4900
6100	240	2132	84	6650	262	7328	289	862	34	902	36	4	3400	3550	3600	3450	3650	3900	4550
6400	252	2232	88	6954	274	7632	300	962	38	1002	39	4	3100	3300	3350	3100	3350	3600	4250
6710	264	2332	92	7261	286	7939	313	1062	42	1102	43	4	2800	3050	3100	2800	3100	3350	3900
7010	276	2432	96	7562	298	8240	324	1162	46	1202	47	4	2550	2800	2850	2500	2800	3050	3650
7310	288	2532	100	7866	310	8544	336	1262	50	1302	51	4	2300	2550	2650	2200	2550	2850	3350
7620	300	2632	104	8170	322	8848	348	1362	54	1402	55	4	2050	2300	2400	1900	2250	2600	3050
7920	312	2732	108	8474	334	9152	360	1462	58	1502	59	4	1800	2050	2150	1650	2000	2350	2750
8230	324	2832	111	8778	346	9456	372	1562	61	1602	63	4	1550	1550	1700	1400	1800	1850	2250
8530	336	2932	115	9082	358	9760	384	1662	65	1702	67	4	1150	1050	1250	1150	1350	1350	1700
8830	348	3032	119	9386	370	10064	396	1762	69	1802	71	4	650	550	750	900	800	800	1150
9140	360	3132	123	9690	381	10368	408	1862	73	1902	75	4	150	50	250	400	250	250	550

E45-70XN2 MAST DIMENSIONS

CLASS 3 MAST														BATTERY COMPARTMENT			
MAXIMUM FORK LIFT (MM)	MAXIMUM FORK LIFT (IN)	LOWERED HEIGHT (MM)	LOWERED HEIGHT (IN)	CUSHION, SMOOTH TIRES								BACK TILT (°)	33	36	40	40	
				EXTENDED HEIGHT WITHOUT LBR (MM)	EXTENDED HEIGHT WITHOUT LBR (IN)	EXTENDED HEIGHT WITH 1220 LBR (MM)	EXTENDED HEIGHT WITH 1220 LBR (IN)	FREE LIFT HEIGHT BOTTOM OF FORKS (MM)	FREE LIFT HEIGHT BOTTOM OF FORKS (IN)	FREE LIFT HEIGHT TOP OF FORKS (MM)	FREE LIFT HEIGHT TOP OF FORKS (IN)		E60XN2	E65XN2	E65XN2	E70XN2	
				CAPACITIES (LBS) @ 24 INCH LOAD CENTER	CAPACITIES (LBS) @ 24 INCH LOAD CENTER	CAPACITIES (LBS) @ 24 INCH LOAD CENTER	CAPACITIES (LBS) @ 24 INCH LOAD CENTER										
2-STAGE LIMITED FREE LIFT																	
2880	113	2032	80	3518	139	4098	161	100	4	150	6	5	6000	6500	6500	7000	
2980	117	2082	82	3618	142	4198	165	100	4	150	6	5	6000	6500	6500	7000	
3080	121	2132	84	3718	146	4298	169	100	4	150	6	5	6000	6500	6500	7000	
3180	125	2182	86	3818	150	4398	173	100	4	150	6	5	6000	6500	6500	7000	
3280	129	2232	88	3918	154	4498	177	100	4	150	6	5	6000	6500	6500	7000	
3380	133	2282	90	4018	158	4598	181	100	4	150	6	5	6000	6500	6500	7000	
3480	137	2332	92	4118	162	4698	185	100	4	150	6	5	6000	6500	6500	7000	
3580	141	2382	94	4218	166	4798	189	100	4	150	6	5	6000	6500	6500	7000	
3680	145	2532	100	4318	170	4898	193	100	4	150	6	5	6000	6500	6500	7000	
3880	153	2632	104	4518	178	5098	201	100	4	150	6	5	6000	6500	6500	7000	
4180	165	2782	110	4818	190	5398	213	100	4	150	6	5	6000	6500	6500	7000	
4480	176	2932	115	5118	201	5698	224	100	4	150	6	5	5900	6400	6400	6900	
4780	188	3182	125	5418	213	5998	236	100	4	150	6	5	5800	6300	6300	6800	
5480	216	3532	139	6118	241	6698	264	100	4	150	6	5	5300	5300	5300	5300	
5880	231	3832	151	6518	257	7098	279	100	4	150	6	5	4450	4450	4450	4450	
2-STAGE FULL FREE LIFT																	
3000	118	2032	80	3632	143	4224	166	1067	42	1117	44	5	6000	6500	6500	7000	
3100	122	2082	82	3732	147	4324	170	1117	44	1167	46	5	6000	6500	6500	7000	
3200	126	2132	84	3832	151	4424	174	1167	46	1217	48	5	6000	6500	6500	7000	
3300	130	2182	86	3932	155	4524	178	1217	48	1267	50	5	6000	6500	6500	7000	
3400	134	2232	88	4032	159	4624	182	1267	50	1317	52	5	6000	6500	6500	7000	
3500	138	2282	90	4132	163	4724	186	1317	52	1367	54	5	6000	6500	6500	7000	
3600	142	2332	92	4232	167	4824	190	1367	54	1417	56	5	6000	6500	6500	7000	
3700	146	2382	94	4332	171	4924	194	1417	56	1467	58	5	6000	6500	6500	7000	
4000	157	2582	102	4632	182	5224	206	1617	64	1667	66	5	6000	6500	6500	7000	
4500	177	2832	111	5132	202	5724	225	1867	74	1917	75	5	5900	6400	6400	6900	
5000	197	3132	123	5632	222	6224	245	2167	85	2217	87	5	5750	6250	6250	6750	
5400	213	3332	131	6032	237	6624	261	2367	93	2417	95	5	5600	6050	6100	6100	
3-STAGE FULL FREE LIFT																	
4320	170	2032	80	4934	194	5538	218	762	30	812	32	5	5950	6450	6450	6950	
4470	176	2082	82	5084	200	5688	224	812	32	862	34	5	5900	6400	6400	6900	
4620	182	2132	84	5234	206	5838	230	862	34	912	36	5	5850	6350	6350	6800	
4770	188	2232	88	5384	212	5988	236	962	38	1012	40	5	5800	6250	6300	6750	
4920	194	2282	90	5534	218	6138	242	1012	40	1062	42	5	5750	6200	6250	6700	
5070	200	2332	92	5684	224	6288	248	1062	42	1112	44	5	5700	6150	6150	6650	
5220	206	2382	94	5834	230	6438	253	1112	44	1162	46	5	5650	6100	6100	6600	
5370	211	2482	98	5984	236	6588	259	1212	48	1262	50	5	5550	6050	6050	6550	
5520	217	2532	100	6134	241	6738	265	1262	50	1312	52	5	5500	6000	6000	6500	
5820	229	2632	104	6434	253	7038	277	1362	54	1412	56	5	5250	5850	5850	6350	
6120	241	2782	110	6734	265	7338	289	1512	60	1562	61	5	4750	5700	5400	5850	
6570	259	2982	117	7184	283	7788	307	1712	67	1762	69	5	4000	4950	4650	5050	
7020	276	3132	123	7634	301	8238	324	1862	73	1912	75	5	3300	4300	3950	4350	
4-STAGE FULL FREE LIFT																	
4840	191	1982	78	5456	215	6060	239	712	28	762	30	4	4300	4750	4650	4850	
5020	198	1982	78	5636	222	6240	246	712	28	762	30	4	4100	4550	4450	4650	
5200	205	1982	78	5816	229	6420	253	712	28	762	30	4	3950	4400	4300	4500	
5430	214	2032	80	6046	238	6650	262	762	30	812	32	4	3750	4200	4050	4250	
5710	225	2132	84	6326	249	6930	273	862	34	912	36	4	3500	4000	3850	4050	
5990	236	2232	88	6606	260	7210	284	962	38	1012	40	4	3300	3800	3600	3800	
6270	247	2332	92	6886	271	7490	295	1062	42	1112	44	4	3050	3600	3400	3600	
6550	258	2432	96	7166	282	7770	306	1162	46	1212	48	4	2850	3350	3200	3400	
6830	269	2532	100	7446	293	8050	317	1262	50	1312	52	4	2650	3200	3000	3200	
7110	280	2632	104	7726	304	8330	328	1362	54	1412	56	4	2450	3000	2800	3000	
7390	291	2732	108	8006	315	8610	339	1462	58	1512	60	4	2250	2800	2600	2800	
7670	302	2832	111	8286	326	8890	350	1562	61	1612	63	4	2050	2600	2400	2600	
7950	313	2932	115	8566	337	9170	361	1662	65	1712	67	4	1850	2450	2200	2450	
8230	324	3032	119	8846	348	9450	372	1762	69	1812	71	4	1650	2300	2050	2250	
8510	335	3132	123	9126	359	9730	383	1862	73	1912	75	4	1450	2100	1850	2050	

FEATURES AND OPTIONS

CONSTRUCTION	STD	OPT
Intelimatch 36V Electrical System	X	
Intelimatch 48V Electrical System		X
Duramatch 48V Electrical System	X	
Duramatch 80V Electrical System		X
Key Switch Start	X	
Keyless Start With Extra Key Under Hood		X
Keyless Start With Operator Password		
Standard Construction - Operating Temps 32 -120	X	
Cooler/Freezer Package [-20 - 120]		X
Battery Compartment Sizes:		
• 4500, 5000, 5500 lb - 27.6" Length	X	
• 4500, 5000, 5500 lb - 30" Length		X
• 4500, 5000, 5500 lb - 33" Length		X
• 6000 Lb - 33" Length	X	
• 6500 Lb - 36" Length	X	
• 6500 Lb - 40" Length		X
• 7000 Lb - 40" Length	X	
UI Class Type E	X	
UI Class Type EE		X
Vertical Lift-Out Battery Removal	X	
Side Battery Removal Without Rollers		X
Battery Spacer		X
Conventional Battery Charging System	X	
Rapid Battery Charging System		X
Lead-Acid Battery Configuration	X	
Lithium-Ion Battery Configuration		X
LIFT OPTIONS - FRONT END EQUIPMENT	STD	OPT
2-Stage Limited Free Lift Mast	X	
2-Stage Full Free Lift Mast		X
3-Stage Full Free Lift Mast		X
4-Stage Full Free Lift Mast		X
Without Mast		X
5-Degree Forward/5-Degree Back Mast Tilt	X	
10-Degree Forward/5-Degree Back Mast Tilt		X
5-Degree Forward/4-Degree Back Mast Tilt		X
Hydraulic Accumulator		X
38.5" Hook Type Carriage	X	
42" Hook Type Carriage		X
38.5" Integral Side Shifting Carriage		X
38.5" Hook Type Attachment Carriage		X
38.5" Hook Type Side Shifting With Fork Positioner		X
42" Hook Type Attachment Carriage		X
Turret Head Attachment Carriage		X
36" Hook Type Standard Taper Forks		X
36" Hook Type Polished & Full Bottom Taper Forks		X
42" Hook Type Standard Taper Forks	X	
42" Hook Type Polished & Full Bottom Taper Forks		X
48" Hook Type Standard Taper Forks		X
48" Hook Type Polished & Full Bottom Taper Forks		X
54" Hook Type Standard Taper Forks		X
60" Hook Type Standard Taper Forks		X
48" Load Backrest	X	
Without Load backrest		X

LIFT OPTIONS - HYDRAULICS	STD	OPT
Mechanical Levers	X	
E-Hydraulic Mini Levers		X
E-Hydraulic Dual Joystick Levers		X
3-Function (1 AUX) Hydraulic Valve	X	
4-Function (2 AUX) Hydraulic Valve		X
Clamping Function		X
3-Function (1 AUX) Hose Group		X
4-Function (2 AUX) Hose Group		X
Without Hose Group	X	
Hydraulic System Monitoring	X	
Hydraulic Pressure Regulator		X
CHASSIS - DRIVE & STEER TIRES	STD	OPT
Standard Tread	X	
Wide Tread		X
Premium Tires	X	
Cushion, Smooth Drive Tires	X	
Non-Marking Cushion, Smooth Drive Tires		X
Cushion, Lug Drive Tires		X
Non-Marking Cushion, Lug Drive Tires		X
Cushion, Smooth Steer Tires	X	
Non-Marking Cushion, Smooth Steer Tires		X
Cushion, Lug Steer Tires		X
Non-Marking Cushion, Lug Steer Tires		X
CHASSIS - OPERATOR COMPARTMENT	STD	OPT
88.5" Grid Style Overhead Guard	X	
86.5" Overhead Guard		X
84.1" Flat Plate Overhead Guard		X
Drive-In Rack Overhead Guard		X
5" Full Color Touch-Screen Display	X	
MONOTROL® Pedal Directional Control		X
Seat-Side Directional Control Switch		X
Auto-Park Brake	X	
Steering Wheel With Spinner Knob	X	
Steering Wheel Without Spinner Knob		X
Infinitely Adjustable Tilt Steer Column	X	
Telescoping Steer Column With Tilt Memory		X
On-Demand Steering	X	
Full Suspension Vinyl Seat	X	
Non-Suspension Vinyl Seat		X
Non-Suspension Cloth Seat		X
Premium Full Suspension Vinyl Seat		X
Premium Full Suspension Cloth Seat		X
Air-Ride Full Suspension Vinyl Seat		X
Air-Ride Full Suspension Cloth Seat		X
Black Seatbelt	X	
Hi-Vis Red Seatbelt		X
Hi-Vis Red Seatbelt With Interlock		X
Hi-Vis Red With Sequential Interlock		X
Traction Speed Limiter - Pre-Set To 8mph Or 8/5 Mph		X
Dynamic Stability System	X	

FEATURES AND OPTIONS

CHASSIS - OPERATOR COMPARTMENT ACCESSORIES	STD	OPT
Dual Side-View Mirrors		X
Panoramic Mirror		X
LED Dome Style Reading Light		X
Rear Drive Handle With Horn Button		X
12V Outlet		X
Fire Extinguisher		X
Load Weight Display		X
Operator Pre-Shift Checklist		X
Programmable Maintenance Reminder		X
Operator Password		X
LIGHTS & ALARMS	STD	OPT
Primary Dc/Dc Converter - Power For Truck Accessories	X	
Auxiliary Dc/Dc Converter - Power For Customer Installed Accessories		X
Without Lights	X	
LED Work Lights - Key Switch Or Automatic Activation		X
One Rear Work Light - Key Switch Or Automatic Activation		X
Two Front Work Lights - Key Switch Or Automatic Activation		X
Two Front / One Rear Work Lights - Key Switch Or Automatic Activation		X
Less Rear Lights	X	
Basic Tail Lights		X
Premium Taillights		X
Blue Or Red Front Spotlight - Continuous Or Directional		X
Blue Or Red Rear Spotlight - Continuous Or Directional		X
Amber Strobe Light		X
Audible Alarm - Reverse		X
Audible Alarm - Forward Or Reverse		X
TECHNOLOGY SOLUTIONS	STD	OPT
Hyster Reaction™		X
Hyster Tracker™ - Standard	X	
Hyster Tracker™ - Advanced		X
Pedestrian Awareness Camera		X



Hyster Company
P.O. Box 7006, Greenville, North Carolina 27835-7006

© 2025 Hyster-Yale Materials Handling, Inc., all rights reserved. Hyster and  are trademarks of Hyster-Yale Materials Handling, Inc. Hyster products are subject to change without notice. Trucks may be shown with optional equipment and/or features not available in all regions.