

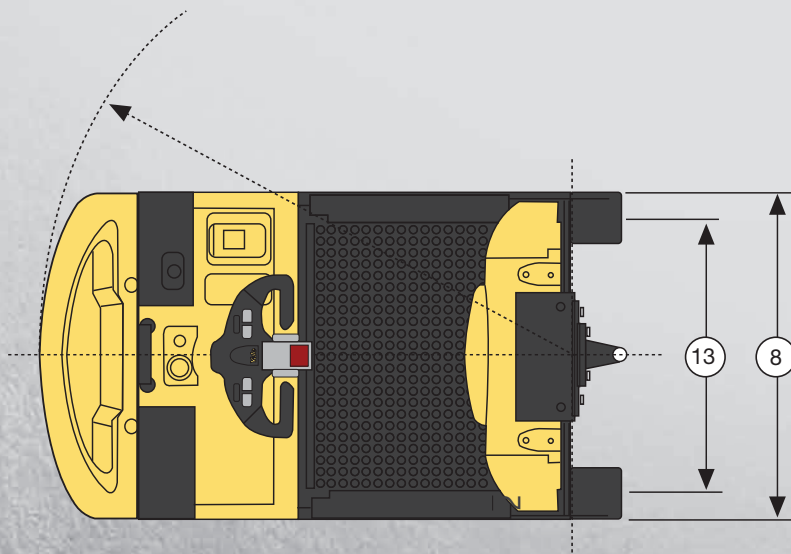

L0100-150T SERIES TECHNICAL GUIDE

WWW.HYSTER.COM

> L0100-150T DIMENSIONS

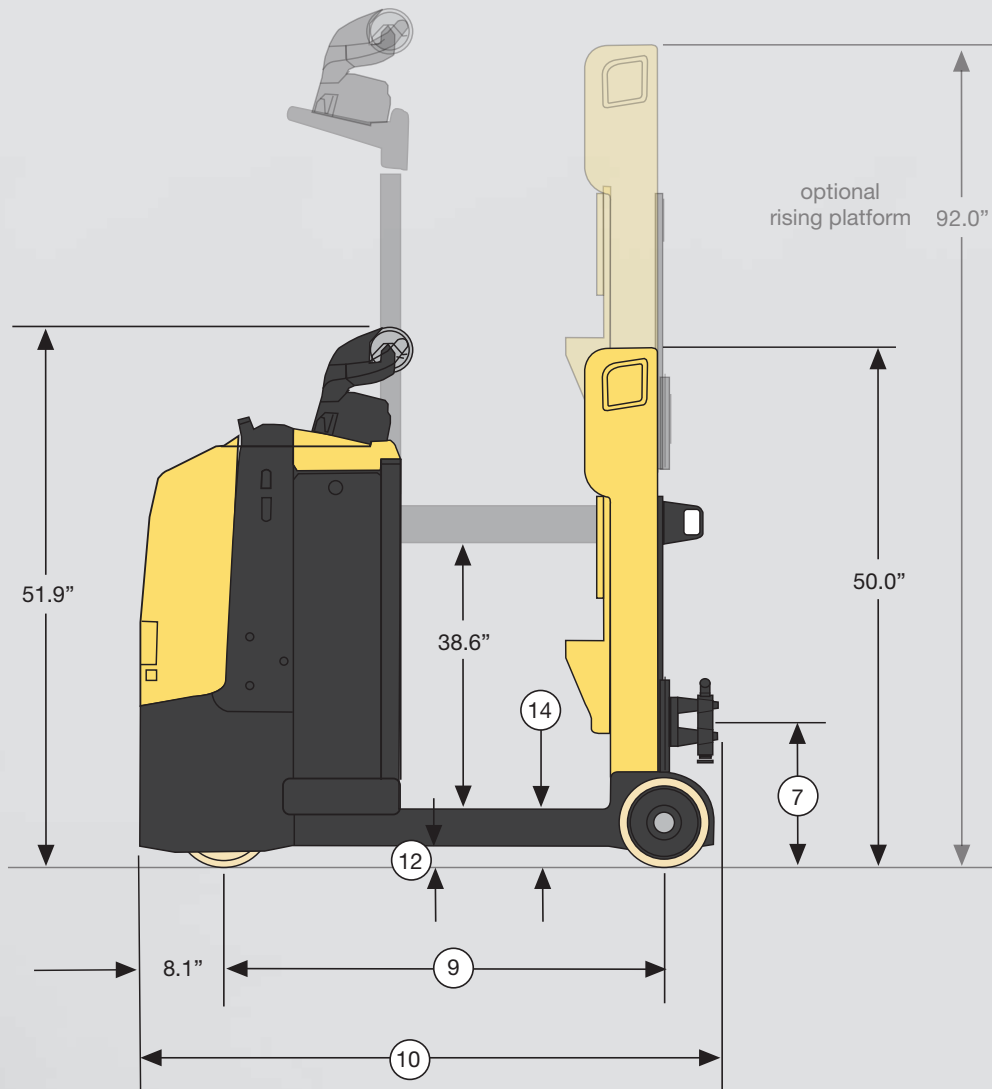

Circled dimensions correspond to the line numbers on the tabulated chart inside the technical guide. Dimensions are in inches (millimeters).

GENERAL	1	Manufacturer		Hyster			
	2	Model designation		LO100	LO150		
	3	Power		Battery			
	4	Voltage		24			
	5	Operation		Stand			
	6	Rated capacity		lb (kg)	10000	15000	
DIMENSIONS	7	Tow pin height	Vertical center of pin	in (mm)	14.3 (365)		
	8	Overall width		in (mm)	31.3		
	9	Wheelbase		in (mm)	42.7 (1084)		
	10	Overall length		in (mm)	56.3 (1429)		
	11	Outside turning radius		in (mm)	50.7 (1289)		
	12	Ground clearance	Center of wheelbase	in (mm)	2 (50)		
	13	Tread width		in (mm)	14.8 (376)		
	14	Step height		in (mm)	6 (152)		
	15	Battery compartment	Height	Std / battery	in (mm)	31.2 x 14.1 x 32 (792 x 357 x 814)	
	16	Floor to top of battery rollers		Side extraction	in (mm)	5.6 (141)	
PERFORMANCE	17	Travel speed	NL/RL	mph (km/h)	8.1 / 4.3 (13 / 7)		
	18	Gradeability	5 minute reading	%	20 / 6		
		Maximum gradeability	5 minute reading	%	20 / 10		
	19	Drawbar pull	5 minute reading	lbf (N)	225 (1000)	299 (1330)	
		Drawbar pull	60 minute reading	lbf (N)	719 (3200)	1011 (4500)	
	20	Brake	Service / parking		Electromagnetic		
WEIGHT	21	Truck weight	w/o battery	NL	lb (kg)	2244.3 (1018)	2455 (1114)
	22	Axle loading		Drive / load wheel	lb (kg)	1539 / 957 (698 / 434)	1765 / 941 (801 / 427)
	23	Battery weight		Min/max	lb (kg)	1005 (456) / 1111 (504)	1005 (456) / 1111 (504)
WHEEL & TIRES	24	Tire type		Drive / steer	Tophane / Polyurethane		
	25	Tire size	Std	Drive / steer	in	10 x 3.5 / 10 x 3.5	
	26	Wheels - number	X=Driven	Drive / steer	1X / 2		
ELECTRIC	27	Battery	Type	Lead Acid			
	28	Traction motor	60 minute rating	hp (kW)	3.5 (2.6)	4.0 (3.0)	
	29	Traction motor		Type / control method	AC / Mosfet		
	30	Number of speeds		Infinitely variable			

Above specifications, unless otherwise listed, are for a standard truck without optional equipment.

BATTERY & COMPARTMENT SPECIFICATIONS

Battery type	Battery compartment dimensions			Battery dimensions			Number of cells	Cell size	Plates per cell	Capacity
	Width	Length	Height	"X"	"Y"	"Z"				6 hour rate
	in (mm)	in (mm)	in (mm)	in (mm)	in (mm)	in (mm)				amp hr (kwh)
Industrial	31.2 (792.0)	14.1 (357.0)	32.0 (814.0)	26.1 (663)	12.8 (325)	23.3 (592)	12	85	11	425 (9.9)
				30.9 (785)	13.0 (330)	23.3 (592)	12	85	13	510 (11.9)
				30.9 (785)	13.0 (330)	26.2 (665)	12	100	13	600 (14.0)
				30.9 (785)	13.0 (330)	30.8 (782)	12	100	13	600 (14.0)

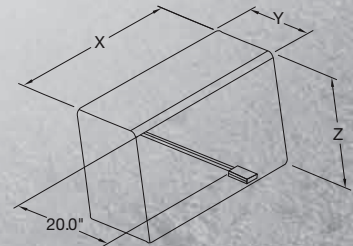

Battery connector: 175 Amp, Red.

Battery lead: Length 20" (508mm), Position "B", 1/0 AWG

CERTIFICATION: Hyster lift trucks meet the design and construction requirements of B56.1-1969, per OSHA Section 1910.178(a)(2), and also comply with the B56.1 revision in effect at time of manufacture. Certification of compliance with the applicable ANSI standards appears on the lift truck.

NOTE: Performance specifications / ratings are for truck equipped as described under Standard Equipment in this Technical Guide. Performance specifications are affected by the condition of the vehicle and how it is equipped, as well as by the nature and condition of the operating area. Specifications are subject to change and the proposed application should be discussed with your authorized Hyster Company Dealer.

> STANDARD FEATURES AND OPTIONS

STANDARD FEATURES

- 31.18 x 14.05 x 32.04" (792 x 357 x 814 mm) battery compartment (for 620 Ah DIN battery)
- Battery removal without rollers - lift out
- 7mph maximum travel speed (unladen)
- Key switch start
- Multipurpose plate for coupling unit
- Dash display with hour meter and graphic battery state of charge indicators
- Handle above operator backrest
- Drive wheel - 10" x 3.5" NDIIthane (LO100)
- Drive wheel - 10" x 3.5" Tophane (LO150)
- 8" x 4" tandem NDIIthane load wheels
- Fixed operator platform
- Scooter steer control
- 12 months / no hour limit full truck warranty (please refer to the full warranty statement for additional details).
- Without battery
- Without charger
- English literature pack and labels
- Regenerative braking
- Adjustable performance settings
- AC traction motor
- Brushless DC steer motor
- Dual-technology Mosfet Combi Controller
- Impact-resistant motor compartment cover
- Sealed Combi Controller (IP65 rating)
- Hall-effect sensors and switches (no wear, no adjustment)
- CANbus communication system
- 1000 hours service intervals

OPTIONAL FEATURES

- Side battery extraction - both sides
- Side battery extraction - left side
- Side battery extraction - right side
- Cold store construction (-22°F)
- Operator password start interlock
- Coupling unit (no holes)
- Hook on multipurpose plate for coupling unit
- Removable hook on multipurpose plate for coupling unit
- Multifunctional display includes: hour meter, graphic battery state of charge indicator, maintenance indicator, alarm with fault code indicators, traction and acceleration reduction mode indicator
- Drive wheel - 10" x 3.5" NDIIthane (LO150)
- 10" x 3.5" Tophane drive wheel (LO100)
- Drive wheel - 10" x 3.5" NDIIthane conductive (LO100 only)
- Drive wheel - 10" x 3.5" NDIIthane antistatic
- 3.3" x 2.7" Tandem polyurethane load wheels
- Clip board
- Coasting function
- Multipurpose bar above motor cover
- Stretch film roll holder
- Trash bin in operator back rest
- Raising operator platform
- Raising operator platform with retractable side arms
- Scooter steer control on lifting platform
- Scooter control on lifting platform with platform control
- Low mounted bumper (rubber bumper)
- Mid mounted bumper (bull bar)
- Hyster Tracker Wireless Access HID Prox Card Reader
- Hyster Tracker Wireless Access iClass MiFare Prox Card Reader
- Hyster Tracker Wireless Access ISO Prox Card Reader
- Hyster Tracker Wireless Monitoring - Cell
- Hyster Tracker Wireless Monitoring - Wifi
- Hyster Tracker Wireless Verification
- Hyster Reaction™ (available on LO100T)
- Audible alarm - reverse direction activated - self-adjusting 82-102 dB(A)
- DC to DC converter - primary - for factory installed options - 25 amps/300 watts @ 12 volts
- Multiple extended protection coverage plans(please refer to the full extended warranty statements for additional details).
- French literature pack and labels
- Spanish literature pack and labels
- Less charger (wired plug included)
- Battery cable extension 59" (1500 mm)
- Twin battery change station



Hyster Company
P.O. Box 7006
Greenville, North Carolina
27835-7006
Part No. LO100-150-TG
4/2022 Litho in U.S.A.

Visit us online at www.hyster.com or call us at **1-800-HYSTER-1**.

© Hyster Company, 2022, all rights reserved. Hyster,  and STRONG PARTNERS. TOUGH TRUCKS. are trademarks of Hyster-Yale Group, Inc.

Hyster products are subject to change without notice. Trucks may be shown with optional equipment.

3012HBC3SP001_E_EN-US_V2R3_042022