



# J40-70XTLG SERIES

---

**INTEGRATED LITHIUM-ION COUNTERBALANCE FORKLIFT**

**TECHNICAL SPECIFICATIONS**

**HYSTER**

A2A6 V10 11MAY 2026

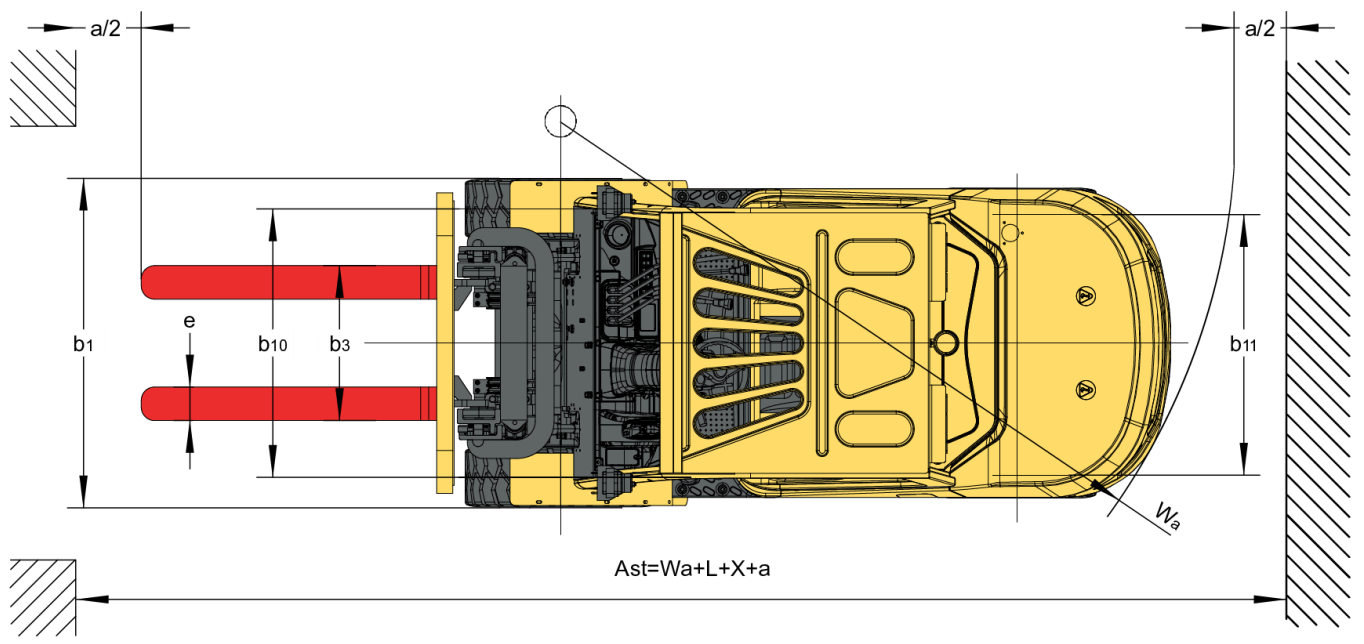
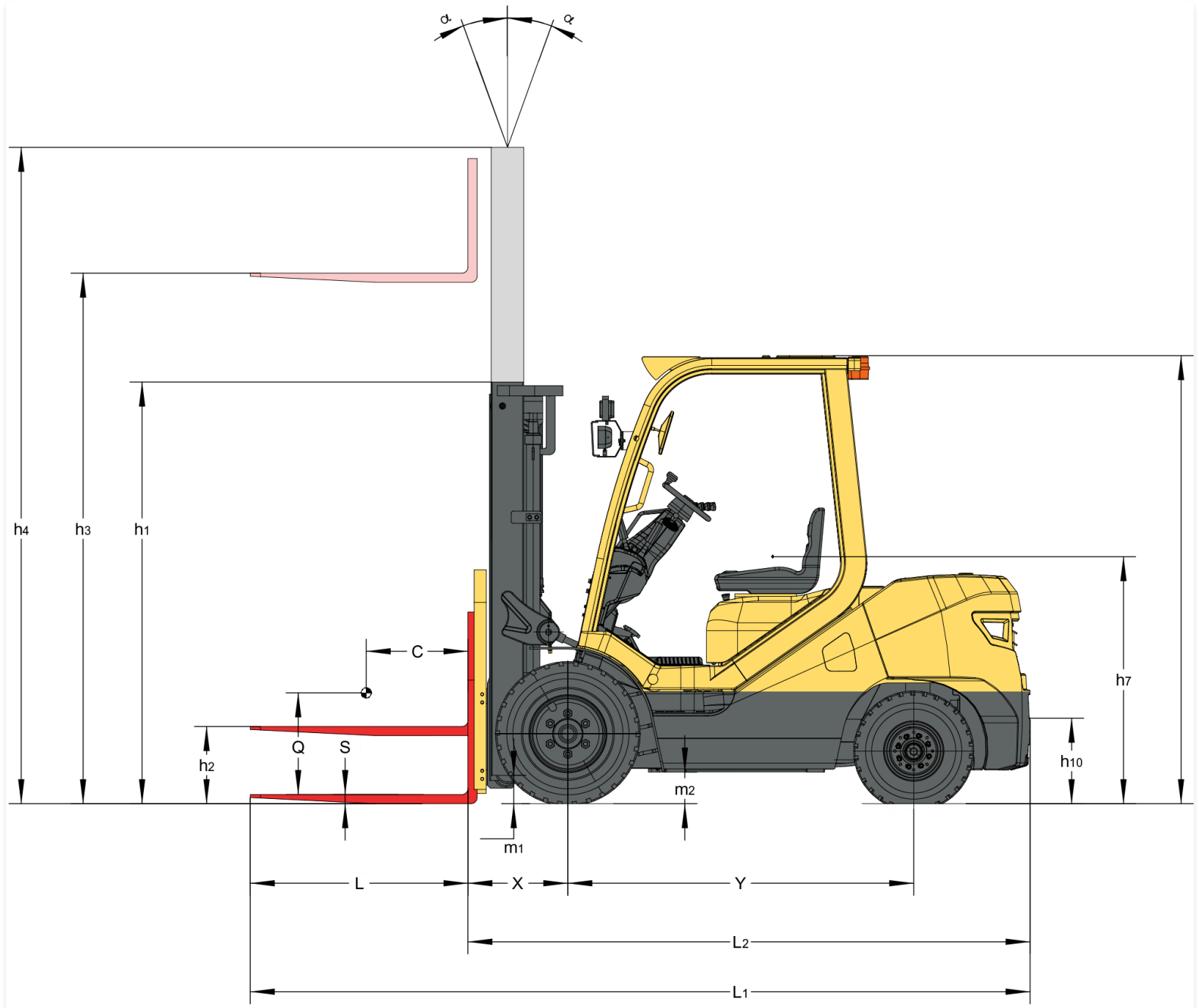

Technical Data											
Specifications Table											
	1.2	Model		J40XTLG	J40XTLG	J50XTLG	J50XTLG	J60XTLG	J60XTLG	J70XTLG	J70XTLG
Distinguishing Mark	1.1	Manufacturer		Hyster	Hyster	Hyster	Hyster	Hyster	Hyster	Hyster	Hyster
	1.3	Drive		Electric	Electric	Electric	Electric	Electric	Electric	Electric	Electric
	1.4	Operator type		Seated	Seated	Seated	Seated	Seated	Seated	Seated	Seated
	1.5	Rated capacity/rated load	Q lb (kg)	4000 (2000)	4000 (2000)	5000 (2500)	5000 (2500)	6000 (3000)	6000 (3000)	7000 (3500)	7000 (3500)
	1.6	Load center distance	c in (mm)	24 (610)	24 (610)	24 (610)	24 (610)	24 (610)	24 (610)	24 (610)	24 (610)
	1.8	Load distance, center of drive axle to fork	x in (mm)	18.74 (476)	18.74 (476)	18.74 (476)	18.74 (476)	19.33 (491)	19.33 (491)	20.07 (510)	20.07 (510)
	1.9	Wheelbase	y in (mm)	63 (1600)	63 (1600)	63 (1600)	63 (1600)	67 (1700)	67 (1700)	67 (1700)	67 (1700)
Weight	2.1	Service weight	lb (kg)	7835 (3554)	8093 (3671)	8408 (3814)	8666 (3931)	9511 (4314)	9603 (4356)	10393 (4714)	10485 (4756)
	2.2	Axle loading, laden front/rear	lb (kg)	10800/1444 (4899/655)	11030/1473 (5003/668)	12277/1642 (5569/745)	12507/1671 (5673/758)	14220/1905 (6450/864)	14304/1914 (6488/868)	15970/2138 (7244/970)	16056/2145 (7283/973)
	2.3	Axle loading, unladen front/rear	lb (kg)	3020/4815 (1370/2184)	3108/4985 (1410/2261)	3274/5135 (1485/2329)	3373/5293 (1530/2401)	3805/5706 (1726/2588)	3840/5763 (1742/2614)	4103/6290 (1861/2853)	4140/6310 (1878/2862)
Tires & chassis	3.1	Tires front/rear		pneumatic	pneumatic	pneumatic	pneumatic	pneumatic	pneumatic	pneumatic	pneumatic
	3.2	Tire size, front		7.00-12-12PR	7.00-12-12PR	7.00-12-12PR	7.00-12-12PR	28×9-15-14PR	28×9-15-14PR	28×9-15-14PR	28×9-15-14PR
	3.3	Tire size, rear		6.00-9-10PR	6.00-9-10PR	6.00-9-10PR	6.00-9-10PR	6.50-10-10PR	6.50-10-10PR	6.50-10-10PR	6.50-10-10PR
	3.5	Wheels, number front/rear		2x/2	2x/2	2x/2	2x/2	2x/2	2x/2	2x/2	2x/2
	3.6	Tread, front	b10 in (mm)	38.2 (970)	38.2 (970)	38.2 (970)	38.2 (970)	39.4 (1000)	39.4 (1000)	39.4 (1000)	39.4 (1000)
	3.7	Tread, rear	b11 in (mm)	38.6 (980)	38.6 (980)	38.6 (980)	38.6 (980)	38.2 (970)	38.2 (970)	38.2 (970)	38.2 (970)
Dimensions	4.1	Tilt of mast/fork carriage, forward/backward	α / β (°)	6/12	6/12	6/12	6/12	6/12	6/12	6/12	6/12
	4.2	Height, mast lowered	h1 in (mm)	79.1 (2010)	79.1 (2010)	79.1 (2010)	79.1 (2010)	84.6 (2150)	84.6 (2150)	84.6 (2150)	84.6 (2150)
	4.3	Free lift	h2 in (mm)	6.3 (160)	6.3 (160)	6.3 (160)	6.3 (160)	6.5 (165)	6.5 (165)	6.7 (170)	6.7 (170)
	4.4	Lift	h3 in (mm)	118.1 (3000)	118.1 (3000)	118.1 (3000)	118.1 (3000)	118.1 (3000)	118.1 (3000)	118.1 (3000)	118.1 (3000)
	4.5	Height, mast extended	h4 in (mm)	140.7 (3575)	140.7 (3575)	140.7 (3575)	140.7 (3575)	143.3 (3640)	143.3 (3640)	145.7 (3700)	145.7 (3700)
	4.7	Height of overhead guard	h6 in (mm)	86 (2180)	86 (2180)	86 (2180)	86 (2180)	87 (2205)	87 (2205)	87 (2205)	87 (2205)
	4.8	Seat height/stand height	h7 in (mm)	47 (1190)	47 (1190)	47 (1190)	47 (1190)	48 (1215)	48 (1215)	48 (1215)	48 (1215)
	4.12	Towing coupling height	h10 in (mm)	9.8 (250)	9.8 (250)	9.8 (250)	9.8 (250)	10.2 (260)	10.2 (260)	10.2 (260)	10.2 (260)

	1.2	MODEL		J40XTLG	J40XTLG	J50XTLG	J50XTLG	J60XTLG	J60XTLG	J70XTLG	J70XTLG
	4.19	Overall length	l1 in (mm)	143 (3630)	143 (3630)	145.3 (3692)	145.3 (3692)	148.1 (3763)	148.1 (3763)	151.7 (3853)	151.7 (3853)
	4.20	Length to face of forks	l2 in (mm)	100.8 (2560)	100.8 (2560)	103.2 (2622)	103.2 (2622)	106 (2693)	106 (2693)	109.6 (2783)	109.6 (2783)
	4.21	Overall width	b1 in (mm)	45.7 (1160)	45.7 (1160)	45.7 (1160)	45.7 (1160)	48.3 (1228)	48.3 (1228)	48.3 (1228)	48.3 (1228)
	4.22	Fork dimensions ISO2331	s/e/l in (mm)	1.6/4.8/42 (40/122/1070)	1.6/4.8/42 (40/122/1070)	1.6/4.8/42 (40/122/1070)	1.6/4.8/42 (40/122/1070)	1.8/4.8/42 (45/122/1070)	1.8/4.8/42 (45/122/1070)	2/4.8/42 (50/122/1070)	2/4.8/42 (50/122/1070)
	4.23	Fork carriage ISO 2328. Class/type, A/B		IIA	IIA	IIA	IIA	IIIA	IIIA	IIIA	IIIA
	4.24	Fork carriage width	b3 in (mm)	40.9 (1040)	40.9 (1040)	40.9 (1040)	40.9 (1040)	43.3 (1100)	43.3 (1100)	43.3 (1100)	43.3 (1100)
	4.31	Ground clearance, laden, below mast	m1 in (mm)	4.9 (125)	4.9 (125)	4.9 (125)	4.9 (125)	5.5 (140)	5.5 (140)	5.5 (140)	5.5 (140)
	4.32	Ground clearance, center of wheelbase	m2 in (mm)	5.1 (130)	5.1 (130)	5.1 (130)	5.1 (130)	6.1 (155)	6.1 (155)	6.1 (155)	6.1 (155)
	4.33	Load dimension b 12 x l 6 crossways	b 12 x l 6 in (mm)	39.4*39.4 (1000*1000)	39.4*39.4 (1000*1000)	39.4*39.4 (1000*1000)	39.4*39.4 (1000*1000)	39.4*39.4 (1000*1000)	39.4*39.4 (1000*1000)	39.4*39.4 (1000*1000)	39.4*39.4 (1000*1000)
	4.34.1	Aisle width with pallets 40 in x 48 in crossways	Ast in (mm)	156.4 (3972)	156.4 (3972)	158.4 (4023)	158.4 (4023)	162.8 (4136)	162.8 (4136)	166.3 (4225)	166.3 (4225)
	4.35	Turning radius	Wa in (mm)	90.4 (2296)	90.4 (2296)	92.4 (2347)	92.4 (2347)	96.3 (2445)	96.3 (2445)	99 (2515)	99 (2515)
	4.36	Inner turning radius	b13 in (mm)	29.3 (745)	29.3 (745)	29.3 (745)	29.3 (745)	32.4 (823)	32.4 (823)	32.4 (823)	32.4 (823)
<b>Performance Data</b>	5.1	Travel speed, laden/unladen	mph (km/h)	9.3/9.3 (15/15)	11.8/11.8 (19/19)	9.3/9.3 (15/15)	11.8/11.8 (19/19)	9.3/9.3 (15/15)	11.8/11.8 (19/19)	9.3/9.3 (15/15)	11.8/11.8 (19/19)
	5.1.1	Travel speed, laden / unladen, backwards	mph (km/h)	7.5/7.5 (12/12)	10/10 (16/16)	7.5/7.5 (12/12)	10/10 (16/16)	7.5/7.5 (12/12)	10/10 (16/16)	7.5/7.5 (12/12)	10/10 (16/16)
	5.2	Lifting speed, laden/unladen	ft/min (mm/s)	79/85 (400/430)	100/106 (510/540)	79/85 (400/430)	100/106 (510/540)	69/75 (350/380)	85/98 (430/500)	69/75 (350/380)	85/98 (430/500)
	5.3	Lowering speed laden/unladen	ft/min (mm/s)	83/98 (420/500)	83/98 (420/500)	83/98 (420/500)	83/98 (420/500)	83/98 (420/500)	83/98 (420/500)	83/98 (420/500)	83/98 (420/500)
	5.5	Drawbar pull laden/unladen	LBF (N)	3596/2922 (16000/13000)	4271/3372 (19000/15000)	3822/3372 (17000/15000)	5170/3597 (23000/16000)	4271/3597 (19000/16000)	5845/3822 (26000/17000)	4271/3597 (19000/16000)	6070/3822 (27000/17000)
	5.8	Maximum gradeability, laden/unladen	%	15/15	20/20	15/15	20/20	15/15	20/20	15/15	20/20
	5.9	Acceleration time, laden/unladen yd 16.4	sec	5.6/5.5	5.6/5.5	5.6/5.5	5.6/5.5	5.6/5.5	5.6/5.5	5.6/5.5	5.6/5.5
	5.10	Service brake		Hydraulic	Hydraulic	Hydraulic	Hydraulic	Hydraulic	Hydraulic	Hydraulic	Hydraulic
<b>Electric Engine</b>	6.1	Drive motor rating S2 60 min	hp (Kw)	20.1 (15)	29 (21.6)	20.1 (15)	29 (21.6)	20.1 (15)	29 (21.6)	20.1 (15)	29 (21.6)

1.2	MODEL			J40XTL6	J40XTL6	J50XTL6	J50XTL6	J60XTL6	J60XTL6	J70XTL6	J70XTL6
	6.2	Lift motor rating at S3 15 %	hp (Kw)	20.1 (15)	30.3 (22.6)	20.1 (15)	30.3 (22.6)	20.1 (15)	30.3 (22.6)	20.1 (15)	30.3 (22.6)
	6.3	Battery according to DIN 43531/35/36 A, B, C, no		no	no	no	no	no	no	no	no
	6.4	Battery voltage/nominal capacity K5	(V)/(Ah)	115.9V/228Ah	154.5V/228Ah	115.9V/228Ah	154.5V/228Ah	115.9V/228Ah	154.5V/228Ah	115.9V/228Ah	154.5V/228Ah
	6.5	Battery weight	lb (kg)	604 (274)	785 (356)	604 (274)	785 (356)	604 (274)	785 (356)	604 (274)	785 (356)
	6.6	Energy consumption according to VDI cycle	kWh/h	4.8	5.7	5.1	6.2	5.8	6.5	6.4	7.1
	6.7	Turnover output	t/h	136.3	163.6	146.4	174.7	166.6	193.9	181.8	212.1
	6.8	Energy consumption at turnover output	kWh in 1 h	5.9	5.9	6.3	6.3	7.2	6.6	7.8	7.2
	8.1	Type of drive unit		PM AC	PM AC	PM AC	PM AC	PM AC	PM AC	PM AC	PM AC
<b>Additional Data</b>	10.1	Operating pressure for attachments	psi (bar)	2030 (140)	2030 (140)	2030 (140)	2030 (140)	2030 (140)	2030 (140)	2030 (140)	2030 (140)
	10.2	Oil volume for attachments	gal/min (l/min)	16.9 (64)	16.9 (64)	16.9 (64)	16.9 (64)	16.9 (64)	16.9 (64)	16.9 (64)	16.9 (64)
	10.7	Sound pressure level at the driver's seat	dB (A)	66	66	66	66	66	66	66	66
	10.7.1	Sound power level during the workcycle	dB (A)	82	81	82	81	82	81	82	81
	10.8	Towing coupling, type DIN		PIN	PIN	PIN	PIN	PIN	PIN	PIN	PIN

**NOTES:**

(4.5) Without load backrest

(4.7) h6 subject to +/-0.2" (5mm) tolerance

(4.8) Full suspension seat in depressed position

(4.24) Add 1.26" (32mm) with load backrest

(10.2) Variable

(10.7.1) LPAZ, measured according to the test cycles and based on the weighting values contained in EN12053

Specification data is based on VDI 2198, with the following configuration: Complete truck with 118.1" (3000mm) 2-stage limited free lift mast, standard carriage and 42" (1070mm) forks, overhead guard and standard pneumatic drive and steer tires. CERTIFICATION: Hyster lift trucks meet the design and construction requirements of B56.1-1969, per OSHA Section 1910.178(a)(2), and also comply with the B56.1 revision in effect at time of manufacture. Certification of compliance with the applicable ANSI standards appears on the lift truck. Performance specifications are for a truck equipped as described under Standard Equipment on this technical guide. Performance specifications are affected by the condition

*of the vehicle and how it is equipped, as well as by the nature, condition of the operating area, proper service and maintenance of the vehicle. If these specifications are critical, the proposed application should be discussed with your dealer.*

MAST DATA										
J40XTLG 4000LBS CAPACITIES @ 24IN LOAD CENTER										
	MAX FORK HEIGHT (IN)	LOWERED HEIGHT (IN)	EXTENDED HEIGHT WITHOUT LBR (IN)	EXTENDED HEIGHT WITH LBR (IN)	FREE LIFT HEIGHT WITHOUT LBR (IN)	BACK TILT (°)	PNEUMATIC SHAPED SOLID TIRES	PNEUMATIC SHAPED SOLID TIRES	PNEUMATIC TIRES	PNEUMATIC TIRES
							Without sideshift (lbs)	With sideshift (lbs)	Without sideshift (lbs)	With sideshift (lbs)
2 Stage Limited Free Lift	118.1	79.1	140.7	157.1	6.3	12	3950	3900	3950	3900
	129.9	85	152.6	168.9	6.3	12	3950	3900	3950	3900
	137.8	89	160.4	176.8	6.3	12	3950	3900	3950	3900
	157.5	100.8	180.1	196.5	6.3	6	3950	3850	3950	3850
2 Stage Full Free Lift	118.1	79.1	141.3	157.1	55.9	12	3950	3850	3950	3850
	129.9	85	153.1	168.9	61.8	12	3950	3800	3950	3800
	137.8	89	161	176.8	65.7	12	3950	3800	3950	3800
3 Stage Full Free Lift	171.3	79.1	191.6	210.2	54.7	6	3700	3600	3700	3600
	177.2	81.1	197.5	216.1	56.7	6	3650	3550	3650	3550
	189	85	209.3	228	60.6	6	3550	3400	3400 (3550~)	3300 (3400~)
	196.9	89	217.2	235.8	64.6	6	3450	3350	3000 (3450~)	2900 (3350~)
	216.5	95.5	236.9	255.5	70.9	6	3250	3150	2100 (3250~)	2000 (3100~)
	236.2	102.8	256.6	275.2	78.3	6	2450 (3050~)	2300 (2900~)	1450 (2600~)	1300 (2500~)
	255.9	111.2	276.3	294.9	87.2	6	1750 (2800~)	1600 (2700~)	950 (1950~)	750 (1800~)
	Max Fork Height (mm)	Lowered Height (mm)	Extended Height without LBR (mm)	Extended Height with LBR (mm)	Free Lift Height without LBR (mm)	Back Tilt (°)				
2 Stage Limited Free Lift	3000	2010	3575	3990	160	12				
	3300	2160	3875	4290	160	12				
	3500	2260	4075	4490	160	12				
	4000	2560	4575	4990	160	6				
2 Stage Full Free Lift	3000	2010	3590	3990	1420	12				
	3300	2160	3890	4290	1570	12				
	3500	2260	4090	4490	1670	12				
3 Stage Full Free Lift	4350	2010	4867	5340	1390	6				
	4500	2060	5017	5490	1440	6				
	4800	2160	5317	5790	1540	6				
	5000	2260	5517	5990	1640	6				
	5500	2425	6017	6490	1800	6				
	6000	2610	6517	6990	1990	6				
	6500	2825	7017	7490	2215	6				

**NOTES:**

Cell with ~ equals dual tread specification

Approximate capacity shown at 24in load center, fork with 42 in and 154V version. Actual truck capacity dependent upon equipped options. Contact your dealer for more information.

J50XTLG 5000LBS CAPACITIES @ 24IN LOAD CENTER

	MAX FORK HEIGHT (IN)	LOWERED HEIGHT (IN)	EXTENDED HEIGHT WITHOUT LBR (IN)	EXTENDED HEIGHT WITH LBR (IN)	FREE LIFT HEIGHT WITHOUT LBR (IN)	BACK TILT (°)	PNEUMATIC SHAPED SOLID TIRES	PNEUMATIC SHAPED SOLID TIRES	PNEUMATIC TIRES	PNEUMATIC TIRES
							Without sideshift (lbs)	With sideshift (lbs)	Without sideshift (lbs)	With sideshift (lbs)
<b>2 Stage Limited Free Lift</b>	118.1	79.1	140.7	157.1	6.3	12	5000	4850	5000	4850
	129.9	85	152.6	168.9	6.3	12	5000	4850	5000	4850
	137.8	89	160.4	176.8	6.3	12	5000	4850	5000	4850
	157.5	100.8	180.1	196.5	6.3	6	4950	4800	4950	4800
<b>2 Stage Full Free Lift</b>	118.1	79.1	141.3	157.1	55.9	12	4950	4800	4950	4800
	129.9	85	153.1	168.9	61.8	12	4950	4800	4950	4800
	137.8	89	161	176.8	65.7	12	4950	4800	4950	4800
<b>3 Stage Full Free Lift</b>	171.3	79.1	191.6	210.2	54.7	6	4050	3900	4050	3900
	177.2	81.1	197.5	216.1	56.7	6	4000	3850	4000	3850
	189	85	209.3	228	60.6	6	3900	3750	3850	3750
	196.9	89	217.2	235.8	64.6	6	3800	3650	3750 (3800~)	3700 (3650~)
	216.5	95.5	236.9	255.5	70.9	6	3550 (3600~)	3450	2800 (3550~)	2700 (3450~)
	236.2	102.8	256.6	275.2	78.3	6	2700 (3350~)	2600 (3250~)	2000 (3250~)	1850 (3150~)
	255.9	111.2	276.3	294.9	87.2	6	1900 (3100~)	1800 (3000~)	1350 (2450~)	1200 (2350~)
	Max Fork Height (mm)	Lowered Height (mm)	Extended Height without LBR (mm)	Extended Height with LBR (mm)	Free Lift Height without LBR (mm)	Back Tilt (°)				
<b>2 Stage Limited Free Lift</b>	3000	2010	3575	3990	160	12				
	3300	2160	3875	4290	160	12				
	3500	2260	4075	4490	160	12				
	4000	2560	4575	4990	160	6				
<b>2 Stage Full Free Lift</b>	3000	2010	3590	3990	1420	12				
	3300	2160	3890	4290	1570	12				
	3500	2260	4090	4490	1670	12				
<b>3 Stage Full Free Lift</b>	4350	2010	4867	5340	1390	6				
	4500	2060	5017	5490	1440	6				
	4800	2160	5317	5790	1540	6				
	5000	2260	5517	5990	1640	6				

	MAX FORK HEIGHT (IN)	LOWERED HEIGHT (IN)	EXTENDED HEIGHT WITHOUT LBR (IN)	EXTENDED HEIGHT WITH LBR (IN)	FREE LIFT HEIGHT WITHOUT LBR (IN)	BACK TILT (°)	PNEUMATIC SHAPED SOLID TIRES	PNEUMATIC SHAPED SOLID TIRES	PNEUMATIC TIRES	PNEUMATIC TIRES
	5500	2425	6017	6490	1800	6				
	6000	2610	6517	6990	1990	6				
	6500	2825	7017	7490	2215	6				

**NOTES:**

Cell with ~ equals dual tread specification

Approximate capacity shown at 24in load center, fork with 42 in and 154V version. Actual truck capacity dependent upon equipped options. Contact your dealer for more information.

J60XTL6 6000LBS CAPACITIES @ 24IN LOAD CENTER

	MAX FORK HEIGHT (IN)	LOWERED HEIGHT (IN)	EXTENDED HEIGHT WITHOUT LBR (IN)	EXTENDED HEIGHT WITH LBR (IN)	FREE LIFT HEIGHT WITHOUT LBR (IN)	BACK TILT (°)	PNEUMATIC SHAPED SOLID TIRES	PNEUMATIC SHAPED SOLID TIRES	PNEUMATIC TIRES	PNEUMATIC TIRES
							Without sideshift (lbs)	With sideshift (lbs)	Without sideshift (lbs)	With sideshift (lbs)
<b>2 Stage Limited Free Lift</b>	118.1	81.7	143.3	161.4	6.5	12	6000	5850	6000	5850
	129.9	87.6	155.1	173.2	6.5	12	6000	5850	6000	5850
	137.8	91.5	163	181.1	6.5	12	6000	5850	6000	5850
	157.5	103.3	182.7	200.8	6.5	6	6000	5800	6000	5800
<b>2 Stage Full Free Lift</b>	118.1	81.7	143.7	161.4	56.1	12	5950	5800	5950	5800
	129.9	87.6	155.5	173.2	62	12	5950	5800	5950	5800
	137.8	91.5	163.4	181.1	65.9	12	5950	5750	5950	5750
<b>3 Stage Full Free Lift</b>	171.3	81.7	194.9	214.6	58.1	6	5500	5350	5500	5350
	177.2	83.7	200.8	220.5	60	6	5450	5300	5450	5300
	189	87.6	212.6	232.3	64	6	5300	5150	5300	5150
	196.9	91.5	220.5	240.2	67.9	6	5200	5050	5050 (5200~)	5000 (5050~)
	216.5	98	240.2	259.8	74	6	4150 (4950~)	4050 (4850~)	3900 (4950~)	3800 (4800~)
	236.2	105.3	259.8	279.5	81.7	6	3150 (4700~)	3000 (4550~)	2950 (4650~)	2850 (4500~)
	255.9	113.8	279.5	299.2	89	6	2300 (4400~)	2150 (4250~)	2150 (3750~)	2050 (3650~)
	<b>Max Fork Height (mm)</b>	<b>Lowered Height (mm)</b>	<b>Extended Height without LBR (mm)</b>	<b>Extended Height with LBR (mm)</b>	<b>Free Lift Height without LBR (mm)</b>	<b>Back Tilt (°)</b>				
<b>2 Stage Limited Free Lift</b>	3000	2075	3640	4100	165	12				
	3300	2225	3940	4400	165	12				
	3500	2325	4140	4600	165	12				
	4000	2625	4640	5100	165	6				
<b>2 Stage Full Free Lift</b>	3000	2075	3650	4100	1425	12				
	3300	2225	3950	4400	1575	12				

	MAX FORK HEIGHT (IN)	LOWERED HEIGHT (IN)	EXTENDED HEIGHT WITHOUT LBR (IN)	EXTENDED HEIGHT WITH LBR (IN)	FREE LIFT HEIGHT WITHOUT LBR (IN)	BACK TILT (°)	PNEUMATIC SHAPED SOLID TIRES	PNEUMATIC SHAPED SOLID TIRES	PNEUMATIC TIRES	PNEUMATIC TIRES
	3500	2325	4150	4600	1675	12				
<b>3 Stage Full Free Lift</b>	4350	2075	4950	5450	1475	6				
	4500	2125	5100	5600	1525	6				
	4800	2225	5400	5900	1625	6				
	5000	2325	5600	6100	1725	6				
	5500	2490	6100	6600	1880	6				
	6000	2675	6600	7100	2075	6				
	6500	2890	7100	7600	2260	6				

**NOTES:**

Cell with ~ equals dual tread specification  
 Approximate capacity shown at 24in load center, fork with 42 in and 154V version. Actual truck capacity dependent upon equipped options. Contact your dealer for more information.

J70XTL6 7000LBS CAPACITIES @ 24IN LOAD CENTER

	MAX FORK HEIGHT (IN)	LOWERED HEIGHT (IN)	EXTENDED HEIGHT WITHOUT LBR (IN)	EXTENDED HEIGHT WITH LBR (IN)	FREE LIFT HEIGHT WITHOUT LBR (IN)	BACK TILT (°)	PNEUMATIC SHAPED SOLID TIRES	PNEUMATIC SHAPED SOLID TIRES	PNEUMATIC TIRES	PNEUMATIC TIRES
							Without sideshift (lbs)	With sideshift (lbs)	Without sideshift (lbs)	With sideshift (lbs)
<b>2 Stage Limited Free Lift</b>	118.1	84.6	145.7	161.4	6.7	12	6900	6800	6900	6800
	129.9	90.6	157.5	173.2	6.7	12	6900	6800	6900	6800
	137.8	94.5	165.4	181.1	6.7	12	6900	6750	6900	6750
	157.5	106.3	185	200.8	6.7	6	6800	6600	6800	6600
<b>2 Stage Full Free Lift</b>	118.1	84.6	144.9	161.4	57.9	12	6900	6800	6900	6800
	129.9	90.6	156.7	173.2	63.8	12	6900	6750	6900	6750
	137.8	94.5	164.6	181.1	67.7	12	6900	6750	6900	6750
<b>3 Stage Full Free Lift</b>	171.3	84.6	196.5	214.6	59.4	6	6900	6800	6900	6800
	177.2	86.6	202.4	220.5	61.4	6	6850	6700	6500 (6850~)	6450 (6700~)
	189	90.6	214.2	232.3	65.4	6	6550 (6700~)	6500 (6550~)	5800 (6700~)	5750 (6550~)
	196.9	94.5	222	240.2	69.3	6	6050 (6600~)	6000 (6450~)	5350 (6600~)	5300 (6450~)
	216.5	101	241.7	259.8	75.4	6	4950 (6350~)	4900 (6200~)	4350 (6150~)	4300 (6150~)
	236.2	108.3	261.4	279.5	83.1	6	4050 (6000~)	3950 (5850~)	3500 (5250~)	3400 (5250~)
	255.9	116.1	281.1	299.2	90.2	6	3200 (5250~)	3150 (5200~)	2800 (4500~)	2700 (4450~)
	<b>Max Fork Height (mm)</b>	<b>Lowered Height (mm)</b>	<b>Extended Height without LBR (mm)</b>	<b>Extended Height with LBR (mm)</b>	<b>Free Lift Height without LBR (mm)</b>	<b>Back Tilt (°)</b>				
<b>2 Stage Limited Free Lift</b>	3000	2150	3700	4100	170	12				

	MAX FORK HEIGHT (IN)	LOWERED HEIGHT (IN)	EXTENDED HEIGHT WITHOUT LBR (IN)	EXTENDED HEIGHT WITH LBR (IN)	FREE LIFT HEIGHT WITHOUT LBR (IN)	BACK TILT (°)	PNEUMATIC SHAPED SOLID TIRES	PNEUMATIC SHAPED SOLID TIRES	PNEUMATIC TIRES	PNEUMATIC TIRES
	3300	2300	4000	4400	170	12				
	3500	2400	4200	4600	170	12				
	4000	2700	4700	5100	170	6				
<b>2 Stage Full Free Lift</b>	3000	2150	3680	4100	1470	12				
	3300	2300	3980	4400	1620	12				
	3500	2400	4180	4600	1720	12				
<b>3 Stage Full Free Lift</b>	4350	2150	4990	5450	1510	6				
	4500	2200	5140	5600	1560	6				
	4800	2300	5440	5900	1660	6				
	5000	2400	5640	6100	1760	6				
	5500	2565	6140	6600	1915	6				
	6000	2750	6640	7100	2110	6				
	6500	2965	7140	7600	2290	6				

**NOTES:**

*Cell with ~ equals dual tread specification*

*Approximate capacity shown at 24in load center, fork with 42 in and 154V version. Actual truck capacity dependent upon equipped options. Contact your dealer for more information.*

**OPTIONS TABLE**

AVAILABLE OPTIONS - NORTH AMERICA

DESCRIPTION	STANDARD	OPTIONAL
<b>PERFORMANCE</b>	<b>STD</b>	<b>OPT</b>
115 Volt electrical system with Rema Connection	X	
154 Volt electrical system with GB Connection		X
Standard Construction	X	
Drum Brakes	X	
Antistatic Strap	X	
115V 228Ah (26.2kWh) Integrated Li-ion battery	X	
115V/100A Three Phase Lithium Ion LFP CACTi charger with REMA160A Connector (input 220V / 480V / 600V)	X	
154V 228Ah(35.1kWh) Integrated Li-ion battery		X
154V/100A Three Phase Lithium Ion LFP CACTi charger with GB 125A Connector (input 220V / 480V / 600V)		X
154V/150A Three Phase Lithium Ion LFP CACTi charger with GB 200A Connector (input 220V / 480V / 600V)		X
Battery Disconnect	X	
<b>OPERATION</b>	<b>STD</b>	<b>OPT</b>
Key Switch Start	X	
Traction Speed Limiter	X	
Operator Presence System (OPS)	X	
Manual Park Brake	X	
<b>DRIVE</b>	<b>STD</b>	<b>OPT</b>
Directional Lever	X	
MONOTROL® Directional Control Pedal		X
Standard Tread	X	
Dual Tread		X
Tyres - Super Elastic		X
Tyres - Super Elastic Non-Marking		X
Tyres - PR Pneumatic	X	
<b>LIFT</b>	<b>STD</b>	<b>OPT</b>
2 Stage Limited Free Lift (LFL)- Class II / III	X	
2 Stage Full Free Lift (FFL) - Class II / III		X
3 Stage Full Free Lift (FFL) - Class II / III		X
Mast tilt - 6° Forward / 12° Back	X	
Mast tilt - 6° Forward / 6° Back		X
With Tilt Cylinder Boots	X	
<b>HANDLING</b>	<b>STD</b>	<b>OPT</b>
Hook Type Carriage - 40.9" (1038mm) Class II	X	
Hook Type Carriage - 43.3" (1100mm) Class III	X	
Hook Type Carriage - 47.2" (1200mm) Class II		X
Hook Type Carriage - 47.2" (1200mm) Class III		X
Hook Type Integral Sideshift Carriage - 40.9" (1040mm) Class II		X
Hook Type Integral Side Shift Carriage - 43.3" (1100mm) Class III		X
Without Carriage		X
Without Load Backrest		X
37.0" (940mm) Load Backrest - Class II		X
42.5" (1080mm) Load Backrest - Class III		X
2 Function (0 Auxiliary) Hydraulic Valve		X
3 Function (1 Auxiliary) Hydraulic Valve	X	
4 Function (2 Auxiliary) Hydraulic Valve		X

DESCRIPTION	STANDARD	OPTIONAL
3 Function Hose Group (1 Auxiliary)		X
4 Function Hose Group (2 Auxiliary)		X
Manual lever hydraulic controls	X	
Clamping Function		X
Hook Type Standard Forks - 42" (1070mm)	X	
Hook Type Standard Forks - 48" (1220mm)		X
Hook Type Standard Forks - 54" (1370mm)		X
Hook Type Standard Forks - 60" (1520mm)		X
Hook Type Standard Forks - 72" (1820mm)		X
Hook Type Standard Forks - 78" (1970mm)		X
Hook Type Standard Forks - 83" (2120mm)		X
Hook Type Standard Forks - 87" (2220mm)		X
Hook Type Standard Forks - 91" (2300mm)		X
Hook Type Standard Forks - 96" (2440mm)		X
<b>CAB</b>	<b>STD</b>	<b>OPT</b>
Full Steel Cab with Heater		X
Cab without Heater		X
Front & Top Cab Panels		X
Front, Top & Rear Cab Panels		X
Dual Mirrors Side View	X	
Rear Drive Handle with Horn Button		X
<b>ERGONOMICS</b>	<b>STD</b>	<b>OPT</b>
85.8" (2180mm) Overhead Guard J40-50XTLG	X	
86.8" (2205mm) Overhead Guard J60-70XTLG	X	
Non Suspension Vinyl Seat	X	
Full Suspension Vinyl Seat with Switch for OPS		X
Standard Seat Belt with Interlock	X	
Steering wheel with spinner knob	X	
<b>VISIBILITY</b>	<b>STD</b>	<b>OPT</b>
LED work lights	X	
2 Front LED Work Lights with Stop, Tail, Indicator & Reverse Lights	X	
2 Front and 1 Rear LED Work Lights with Stop, Tail, Indicator & Reverse Lights		X
Amber Strobe Light - Ignition and Switch Activated		X
Audible Reverse Alarm		X
Parking Alarm	X	
<b>APPEARANCE</b>	<b>STD</b>	<b>OPT</b>
Hyster yellow paint base truck	X	
<b>SUPPLEMENTAL</b>	<b>STD</b>	<b>OPT</b>
12 month / 2,000 hour full truck warranty	X	
36 month / 6,000 hour powertrain warranty	X	
5 years / 3000 cycles Integrated Li-ion Battery Warranty	X	
2 years Li-ion Charger Warranty	X	
Operating manual	X	



DC OUTPUT SPECS	PART NUMBER	81023941	81023942	69203234	69208857	81023862	69203235	69208858
	Ingress Protection Rating	IP54	IP54	IP54	IP54	IP54	IP54	IP54
<b>Other</b>	3rd Party Rating	UL 1564 Compliant	UL 1564 Compliant	UL 1564 Compliant	UL 1564 Compliant	UL 1564 Compliant	UL 1564 Compliant	UL 1564 Compliant
	Warranty Term****	Yes	Yes	Yes	Yes	Yes	Yes	Yes

**NOTES:**

\* Periodic full discharge and charge needed to balance cells and maintain battery warranty. See full warranty statement for complete details

\*\* Short circuit, overcurrent, overvoltage, reverse connection, current backflow protection, isolation

\*\*\* Breaker typically 25% greater than input current, consult electrical professional for your situation

\*\*\*\*2 Year Warranty, Terms and Conditions Apply. See full warranty statement for complete details.



HYSTER COMPANY

P.O. BOX 7367

GREENVILLE, NC 27835-7367

U.S.A.

[HYSTER.COM](http://HYSTER.COM)

© 2026 HYSTER-YALE MATERIALS HANDLING, INC., ALL RIGHTS RESERVED. HYSTER AND [LOGO] ARE TRADEMARKS OF HYSTER-YALE MATERIALS HANDLING, INC. TRUCKS MAY BE SHOWN WITH OPTIONAL EQUIPMENT AND/OR FEATURES NOT AVAILABLE IN ALL REGIONS. TRUCK PERFORMANCE MAY BE AFFECTED BY THE CONDITION OF THE VEHICLE, HOW IT IS EQUIPPED AND THE APPLICATION. SPECIFICATIONS ARE SUBJECT TO CHANGE WITHOUT NOTICE. CONSULT YOUR HYSTER® DEALER IF ANY OF THE INFORMATION SHOWN IS CRITICAL TO YOUR APPLICATION. CERTIFICATION: HYSTER LIFT TRUCKS MEET THE DESIGN AND CONSTRUCTION REQUIREMENTS OF B56.1-1969, PER OSHA SECTION 1910.178(A)(2), AND ALSO COMPLY WITH THE B56.1 REVISION IN EFFECT AT TIME OF MANUFACTURE.