



J80-110XTLG SERIES

INTEGRATED LITHIUM-ION COUNTERBALANCE FORKLIFT

TECHNICAL SPECIFICATIONS

HYSTER

A2A7 V1R0 11/05/2026

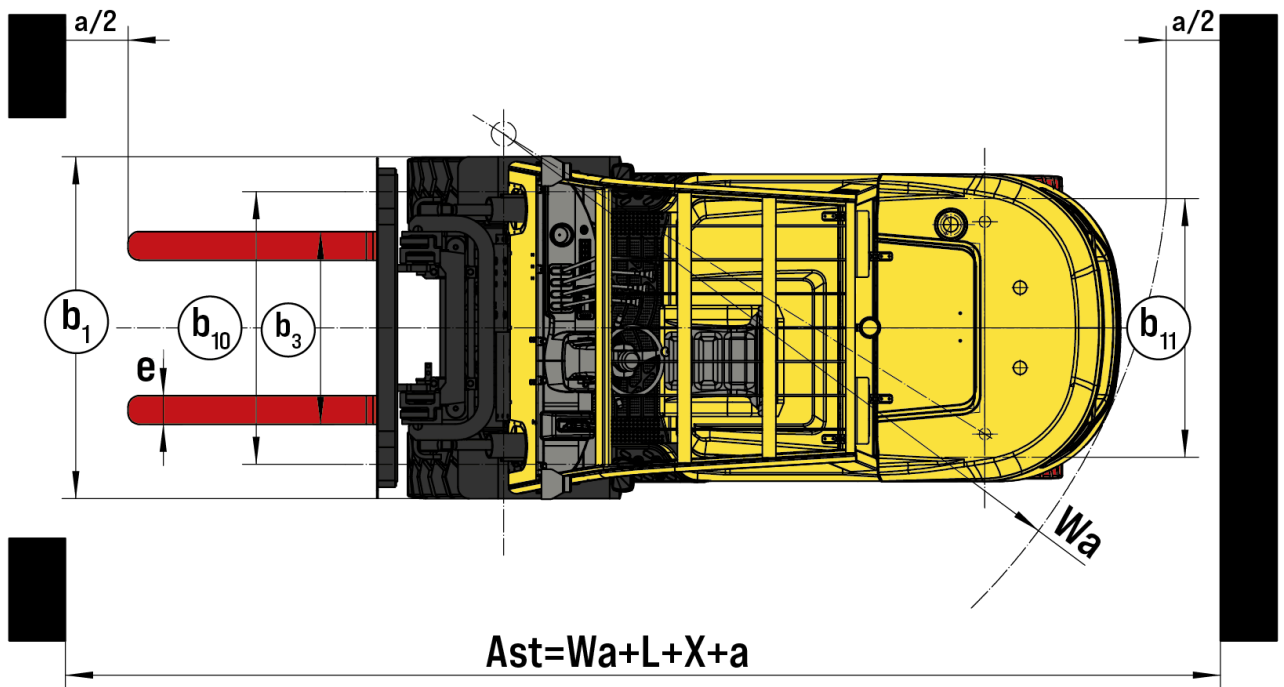
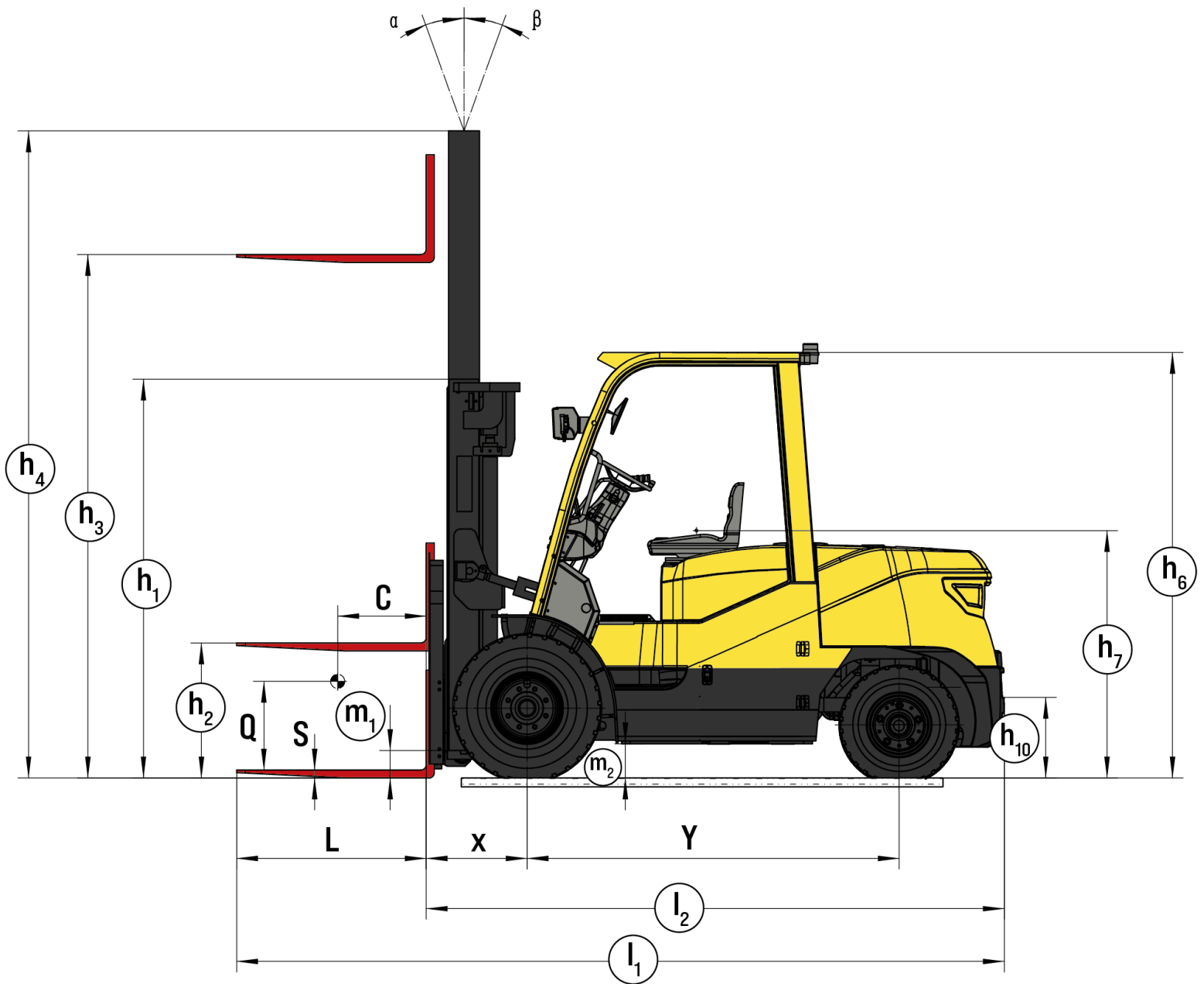

TECHNICAL DATA

TECHNICAL DATA

	1.2	Model designation		J80XTLG	J90XTLG	J100XTLG	J110XTLGS
Distinguishing mark	1.1	Manufacturer		Hyster	Hyster	Hyster	Hyster
	1.3	Drive		Electric	Electric	Electric	Electric
	1.4	Operator type		Seated	Seated	Seated	Seated
	1.5	Rated capacity/rated load	Q (lb)	8003	9193	10097	10582
	1.6	Load center distance	c (in)	24.0	24.0	24.0	24.0
	1.8	Load distance, center of drive axle to fork	x (in)	22.7	22.7	22.9	23.0
	1.9	Wheelbase (with mast vertical)	y (in)	82.7	82.7	82.7	82.7
Weight	2.1	Service weight	lb	14429	14947	15796	16347
	2.2	Axle loading, laden front/rear	lb	20819/2380	22355/2396	24191/2572	24085/3285
	2.3	Axle loading, unladen front/rear	lb	6493/7936	6865/8082	6940/8856	7354/8993
tires, chassis	3.1	Tires		Pneumatic Shaped Solid	Pneumatic Shaped Solid	Pneumatic Shaped Solid	Pneumatic Shaped Solid
	3.2	Tire size, front		300-15-18PR	300-15-18PR	300-15-18PR	300-15-18PR
	3.3	Tire size, rear		7.00-12-12PR	7.00-12-12PR	7.00-12-12PR	7.00-12-14PR
	3.5	Wheels, number front/rear		2x2	2x2	2x2	2X2
	3.6	Tread, front	b10 (in)	46.9	46.9	46.9	46.9
	3.7	Tread, rear	b11 (in)	44.5	44.5	44.5	44.5
Dimensions	4.1	Tilt of mast/fork carriage, forward /backward	α / β (°)	6/12	6/12	6/12	6/12
	4.2	Height, mast lowered	h1 (in)	88.7	88.7	88.7	88.7
	4.3	Free lift	h2 (in)	5.9	5.9	6.1	6.3
	4.4	Lift	h3 (in)	118.2	118.2	118.2	118.2
	4.5	Height, mast extended	h4 (in)	167.8	167.8	167.8	174.1
	4.7	Height of overhead guard (Low / High)	h6 (in)	88.7 / 94.5	88.7 / 94.5	88.7 / 94.5	88.7 / 94.5
	4.8	Seat height/stand height	h7 (in)	53.2	53.2	53.2	53.2
	4.12	Towing coupling height	h10 (in)	13.4	13.4	13.4	13.4
	4.19	Overall length	l1 (in)	168.6	168.6	171.2	178.5
	4.20	Length to face of forks	l2 (in)	126.5	126.5	129.0	130.4
	4.21	Overall width, Std/Dual	b1/b2 (in)	58.7/75.7	58.7/75.7	58.7/75.7	58.7/75.7
	4.22	Fork dimensions ISO2331	s/e/l (in)	1.97/5.9/42.1	1.97/5.9/42.1	1.97/5.9/42.1	2.36/5.9/48
	4.23	Fork carriage ISO 2328. Class/type, A/B		ISO 3A	ISO 3A	ISO 3A	ISO 4A
	4.24	Fork carriage width	b3 (in)	54.4	54.4	54.4	54.4
	4.31	Ground clearance, laden, below mast	m1 (in)	5.1	5.1	5.1	5.1

	1.2	Model designation		J80XTLG	J90XTLG	J100XTLG	J110XTLGS
	4.32	Ground clearance, center of wheelbase	m2 (in)	7.3	7.3	7.3	7.3
	4.33	Load dimension b 12*/6 crossways	b12*16(in)	39.4x39.4	39.4x39.4	39.4x39.4	39.4x39.4
	4.34	Aisle width with no load dimensions	Ast (in)	142.7	142.7	145.1	150.2
	4.34.1	Aisle width with pallets 39.4" x 47.2" crossways	Ast (in)	182.2	182.2	184.6	185.8
	4.34.2	Aisle width with pallets 31.5" x 47.2" lengthways	Ast (in)	190.1	190.1	192.5	193.7
	4.35	Turning radius	Wa (in)	112.3	112.3	114.5	115.4
	4.36	Internal turning radius	b13 (in)	33.3	33.3	33.3	33.3
Performance data	5.1	Travel speed, laden/unladen	mi/h	11.2/11.2	11.2/11.2	11.2/11.2	11.2/11.2
	5.1.1	Travel speed, laden/unladen, backwards	mi/h	8.7/8.7	8.7/8.7	8.7/8.7	8.7/8.7
	5.2	Lifting speed, laden/unladen	ft/s	1.31/1.57	1.31/1.57	1.31/1.57	1.31/1.57
	5.3	Lowering speed laden/unladen	ft/s	1.57/1.64	1.57/1.64	1.57/1.64	1.57/1.64
	5.6	Max. drawbar pull laden/unladen	lbf	7419/5620	7419/5620	7419/5620	7419/5620
	5.7	Gradeability, laden/unladen	%	20/25	20/25	20/25	20/25
	5.9	Acceleration time, laden/unladen	sec	6.1/5.14	6.1/5.14	6.1/5.14	6.1/5.14
	5.10	Service brake		Hydraulic	Hydraulic	Hydraulic	Hydraulic
Electric-Motor	6.1	Drive Motor Rating, S2, 60min	hp/rpm	40.2hp/2400rpm	40.2hp/2400rpm	40.2hp/2400rpm	40.2hp/2400rpm
	6.2	Lifting motor rating at S3 15%	hp	33.5	33.5	33.5	33.5
	6.3	Battery according to DIN 43531/35/36 A, B, C, no		No	No	No	No
	6.4	Battery voltage/nominal capacity (5hr rate)	V/Ah	154.5V302Ah (HYG)	154.5V302Ah (HYG)	154.5V302Ah (HYG)	154.5V302Ah (HYG)
	6.5	Battery weight	lb	941.4	941.4	941.4	941.4
	6.6	Energy consumption according to VDI cycle	kWh/h	12.19	12.63	13.35	13.81
	6.7	Turnover output	t/h	163.1	168.7	178.2	184.4
	6.8	Energy consumption at turnover output	t/kWh	8.5	8.8	9.3	9.6
	8.1	Type of drive unit		PM AC	PM AC	PM AC	PM AC
Additional data	10.1	Operating pressure for attachments	psi	2828.0	2828.0	2828.0	2828.0

	1.2	Model designation		J80XTLG	J90XTLG	J100XTLG	J110XTLGS
	10.2	Oil volume for attachments	gpm	18.5	18.5	18.5	18.5
	10.7	Sound pressure level at the driver's seat	dB (A)	69.4	69.4	69.4	69.4
	10.7.1	Sound power level during the workcycle	dB	86.2	86.2	86.2	86.2
	10.8	Towing coupling, type DIN		PIN	PIN	PIN	PIN

NOTES:

(4.5) Without load backrest

(4.7) h6 subject to +/-0.2" (5mm) tolerance

(4.8) Full suspension seat in depressed position

(4.24) Add 1.26" (32mm) with load backrest

(10.2) Variable

(10.7.1) LPAZ, measured according to the test cycles and based on the weighting values contained in EN12053

Specification data is based on VDI 2198, with the following configuration: Complete truck with 118.1" (3000mm) 2-stage limited free lift mast, standard carriage and 42" (1070mm) forks, overhead guard and standard pneumatic drive and steer tires. CERTIFICATION: Hyster lift trucks meet the design and construction requirements of B56.1-1969, per OSHA Section 1910.178(a)(2), and also comply with the B56.1 revision in effect at time of manufacture. Certification of compliance with the applicable ANSI standards appears on the lift truck. Performance specifications are for a truck equipped as described under Standard Equipment on this technical guide. Performance specifications are affected by the condition of the vehicle and how it is equipped, as well as by the nature, condition of the operating area, proper service and maintenance of the vehicle. If these specifications are critical, the proposed application should be discussed with your dealer.

MAST DIMENSIONS

J80XTLG MAX CAPACITY@MFH LC 24" - FRONT SINGLE PNEUMATIC SHAPED SOLID TIRE

Range	Max.Lift Height	Lowered Height (in)	Extended Height without LBR (in)	Extended Height with LBR (in)	Free Lift Height without LBR (in)	Tilt	Without sideshift (lb)	With 54" Integral Sideshift Carriage (lb)	With 54" Hang on Sideshift Carriage (lb)	56" Integral Sideshift Carriage and Fork Positioner (lb)
2LFL	118.1	88.6	151.8	167.7	5.9	6°/12°	8000	7700	7400	7300
	129.9	94.5	163.6	179.5	5.9	6°/12°	8000	7700	7400	7200
	137.8	98.4	171.5	187.4	5.9	6°/12°	8000	7700	7400	7200
	145.7	102.4	181.3	197.2	5.9	6°/12°	7900	7700	7300	7200
	157.5	110.2	191.1	207.1	5.9	6°/12°	7800	7500	7200	7100
	177.2	120.1	210.8	226.8	5.9	6°/6°	7600	7300	7000	6900
	196.9	129.9	230.5	246.5	5.9	6°/6°	7300	7100	6800	6600
	216.5	141.7	250.2	266.1	5.9	3°/6°	6500	6400	6300	6100
	236.2	151.6	269.9	285.8	5.9	3°/6°	5600	5500	5400	5200
2FFL	118.1	88.6	151.8	167.3	56.1	6°/12°	8000	7700	7400	7300
	129.9	94.5	163.6	179.1	62.0	6°/12°	8000	7700	7400	7300
	137.8	98.4	171.5	187.0	65.9	6°/12°	8000	7700	7400	7200
	147.6	103.3	181.3	196.9	70.9	6°/12°	8000	7700	7400	7200
	157.5	110.2	191.1	206.7	77.8	6°/12°	7800	7500	7300	7100
3FFL	157.5	83.1	192.1	207.3	50.2	6°/6°	7400	7100	6900	6700
	171.3	88.0	205.9	221.1	54.9	6°/6°	7300	7000	6700	6600
	177.2	90.0	212.0	227.2	57.1	6°/6°	7200	6900	6700	6500
	189.0	93.9	223.8	239.0	60.8	6°/6°	7100	6800	6500	6400
	196.9	97.8	231.5	246.7	64.8	6°/6°	6800	6600	6400	6300
	212.6	102.8	247.0	262.2	69.7	3°/6°	6200	6000	5800	5700
	236.2	112.2	270.7	285.8	79.1	3°/6°	5200	5100	4900	4800
	255.9	120.1	290.4	305.5	87.0	3°/6°	4500	4400	4300	4100

J90XTLG MAX CAPACITY@MFH LC 24" - FRONT SINGLE PNEUMATIC SHAPED SOLID TIRE

Mast Type	Max.Lift Height	Lowered Height (in)	Extended Height without LBR (in)	Extended Height with LBR (in)	Free Lift Height without LBR (in)	Tilt	Standard Carriage(lb)	54" Integral Sideshift Carriage (lb)	54" Hang on Sideshift Carriage (lb)	56" Integral Sideshift Carriage and Fork Positioner (lb)
2LFL	118.1	88.6	151.8	167.7	5.9	6°/12°	9200	8800	8500	8400
	129.9	94.5	163.6	179.5	5.9	6°/12°	9200	8800	8500	8400
	137.8	98.4	171.5	187.4	5.9	6°/12°	9100	8800	8500	8300
	145.7	102.4	181.3	197.2	5.9	6°/12°	9100	8800	8500	8300
	157.5	110.2	191.1	207.1	5.9	6°/12°	9000	8600	8300	8200
	177.2	120.1	210.8	226.8	5.9	6°/6°	8700	8400	8100	7900
	196.9	129.9	230.5	246.5	5.9	6°/6°	8300	8100	7800	7700
	216.5	141.7	250.2	266.1	5.9	3°/6°	7200	7100	6900	6800
	236.2	151.6	269.9	285.8	5.9	3°/6°	6200	6100	6000	5800
2FFL	118.1	88.6	151.8	167.3	56.1	6°/12°	9000	8700	8400	8200
	129.9	94.5	163.6	179.1	62.0	6°/12°	9000	8700	8300	8200

Mast Type	Max.Lift Height	Lowered Height (in)	Extended Height without LBR (in)	Extended Height with LBR (in)	Free Lift Height without LBR (in)	Tilt	Standard Carriage(lb)	54" Integral Sideshift Carriage (lb)	54" Hang on Sideshift Carriage (lb)	56" Integral Sideshift Carriage and Fork Positioner (lb)
	137.8	98.4	171.5	187.0	65.9	6°/12°	9000	8600	8300	8200
	147.6	103.3	181.3	196.9	70.9	6°/12°	9000	8600	8300	8200
	157.5	110.2	191.1	206.7	77.8	6°/12°	8800	8500	8200	8000
3FFL	157.5	83.1	192.1	207.3	50.2	6°/6°	8300	8000	7700	7600
	171.3	88.0	205.9	221.1	54.9	6°/6°	8200	7900	7600	7400
	177.2	90.0	212.0	227.2	57.1	6°/6°	8100	7800	7500	7300
	189.0	93.9	223.8	239.0	60.8	6°/6°	7600	7300	7100	7000
	196.9	97.8	231.5	246.7	64.8	6°/6°	7200	7000	6800	6700
	212.6	102.8	247.0	262.2	69.7	3°/6°	6600	6400	6200	6100
	236.2	112.2	270.7	285.8	79.1	3°/6°	5600	5500	5300	5200
	255.9	120.1	290.4	305.5	87.0	3°/6°	4900	4800	4700	4500

J100XTLG MAX CAPACITY@MFH LC 24" - FRONT SINGLE PNEUMATIC SHAPED SOLID TIRE

Mast Type	Max.Lift Height	Lowered Height (in)	Extended Height without LBR (in)	Extended Height with LBR (in)	Free Lift Height without LBR (in)	Tilt	Standard Carriage(lb)	54" Integral Sideshift Carriage (lb)	54" Hang on Sideshift Carriage (lb)	56" Integral Sideshift Carriage and Fork Positioner (lb)
2LFL	118.1	88.6	151.8	167.7	6.1	6°/12°	10100	9700	9400	9200
	129.9	94.5	163.6	179.5	6.1	6°/12°	10100	9700	9400	9200
	137.8	98.4	171.5	187.4	6.1	6°/12°	10100	9700	9300	9200
	145.7	102.4	181.3	197.2	6.1	6°/12°	10100	9700	9300	9200
	157.5	110.2	191.1	207.1	6.1	6°/12°	9900	9500	9200	9000
	177.2	120.1	210.8	226.8	6.1	6°/6°	9600	9300	9000	8800
	196.9	129.9	230.5	246.5	6.1	6°/6°	9200	9000	8700	8600
	216.5	141.7	250.2	266.1	6.1	3°/6°	8000	7900	7700	7600
	236.2	151.6	269.9	285.8	6.1	3°/6°	7000	6900	6700	6600
2FFL	118.1	88.6	151.8	167.3	56.3	6°/12°	10100	9700	9300	9200
	129.9	94.5	163.6	179.1	62.2	6°/12°	10100	9700	9300	9200
	137.8	98.4	171.5	187.0	66.1	6°/12°	10000	9700	9300	9200
	147.6	103.3	181.3	196.9	71.1	6°/12°	10000	9600	9300	9100
	157.5	110.2	191.1	206.7	78.0	6°/12°	9900	9500	9200	9000
3FFL	157.5	83.1	192.1	207.3	50.4	6°/6°	9200	8900	8500	8400
	171.3	88.0	205.9	221.1	55.1	6°/6°	9000	8700	8400	8200
	177.2	90.0	212.0	227.2	57.3	6°/6°	9000	8600	8300	8200
	189.0	93.9	223.8	239.0	61.0	6°/6°	8400	8200	8000	7800
	196.9	97.8	231.5	246.7	65.0	6°/6°	8100	7800	7600	7500
	212.6	102.8	247.0	262.2	69.9	3°/6°	7400	7200	7000	6800
	236.2	112.2	270.7	285.8	79.3	3°/6°	6400	6200	6100	5900
	255.9	120.1	290.4	305.5	87.2	3°/6°	5600	5500	5300	5200

J110XTLGS MAX CAPACITY@MF LC 24" - FRONT SINGLE PNEUMATIC SHAPED SOLID TIRE

Mast Type	Max.Lift Height	Lowered Height (in)	Extended Height without LBR (in)	Extended Height with LBR (in)	Free Lift Height without LBR (in)	Tilt	Standard Carriage(lb)	54" Integral Sideshift Carriage (lb)	54" Hang on Sideshift Carriage (lb)	56" Integral Sideshift Carriage and Fork Positioner (lb)
2LFL	118.1	88.6	151.8	174.0	6.3	6°/12°	10600	10600	10600	10500
	129.9	94.5	163.6	185.8	6.3	6°/12°	10600	10600	10600	10500
	137.8	98.4	171.5	193.7	6.3	6°/12°	10600	10600	10600	10500
	145.7	102.4	181.3	203.5	6.3	6°/12°	10600	10600	10600	10400
	157.5	110.2	191.1	213.4	6.3	6°/12°	10500	10500	10500	10300
	177.2	120.1	210.8	233.1	6.3	6°/6°	10300	10300	10200	10100
	196.9	129.9	230.5	252.8	6.3	6°/6°	9600	9400	9100	8900
	216.5	141.7	250.2	272.4	6.3	3°/6°	8400	8300	7900	7800
	236.2	151.6	269.9	292.1	6.3	3°/6°	7300	7200	6900	6700
	2FFL	118.1	88.6	151.8	173.6	56.5	6°/12°	10600	10600	10400
129.9		94.5	163.6	185.4	62.4	6°/12°	10600	10600	10400	10200
137.8		98.4	171.5	193.3	66.3	6°/12°	10600	10600	10400	10200
147.6		103.3	181.3	203.1	71.3	6°/12°	10600	10600	10400	10200
157.5		110.2	191.1	213.0	78.1	6°/12°	10500	10500	10300	10100
3FFL	157.5	83.1	192.1	213.6	50.6	6°/6°	10000	9600	9100	8900
	171.3	88.0	205.9	227.4	55.3	6°/6°	9800	9500	8900	8700
	177.2	90.0	212.0	233.5	57.5	6°/6°	9600	9300	8800	8600
	189.0	93.9	223.8	245.3	61.2	6°/6°	9000	8700	8300	8200
	196.9	97.8	231.5	253.0	65.2	6°/6°	8700	8400	8000	7900
	212.6	102.8	247.0	268.5	70.1	3°/6°	8000	7700	7300	7200
	236.2	112.2	270.7	292.1	79.5	3°/6°	7100	6800	6400	6300
	255.9	120.1	290.4	311.8	87.4	3°/6°	6300	6100	5700	5600

HYSTER LITHIUM-ION BATTERY SPECIFICATIONS

Description	Units	
Nominal Voltage	V	154.6
Chemistry		Lithium Iron Phosphate (LFP)
Nominal Energy Capacity	kWh	272
Charging Temperature	°F [°C]	32 to 113 (0 to 45)
Operating Temperature	°F [°C]	14 to 113 (-10 to 45)
IP Rating		IP54
3rd Party Rating		UL Listed

NOTES:

* Operating performance may be restricted below -14 F please consult the Operator Manual.

HYSTER LITHIUM-ION CHARGER SPECIFICATIONS

	Item	Unit				
DC Output Specs	Part Number	-	81023942	69208857	69208858	81023862
	Rated Output Voltage	V	154	154	154	154
	Output current	A	100	100	100	150
	Typical output power	kW	15.4	15.4	15.4	23.1
	20-80% Charge Time Estimate	h	1.8	1.8	1.8	1.2
	Output Connector		GB/T	GB/T	GB/T	GB/T
	Protection	-	->	->	->	->
3 Phase AC Input Specs	Input Voltage	VAC	220	480	600	480
	Input Current	A	59.7	27.4	21.9	30.4
	Typical Grid Power Required	KVA	22.5	22.6	22.5	25.0
	Cable Length / Connector	ft (m)	10 (3) / Customer Provided Connector	10 (3) / Customer Provided Connector	10 (3) / Customer Provided Connector	10 (3) / Customer Provided Connector
Form Factor	Exterior Dimensions (LxWxH)	in (mm)	22x13x44 (558x353x1128)	24x17x32 (618x435x815)	24x17x43 (618x430x1100)	24x17x32 (618x435x815)
	Weight	lb (kg)	297 (135)	165 (75)	359 (163)	165 (75)
Environmental Conditions	Working environment temperature	°F (°C)	-22 to 158°F (-30 to 70°C)	-22 to 158°F (-30 to 70°C)	-22 to 158°F (-30 to 70°C)	-22 to 158°F (-30 to 70°C)
	Storage temperature	°F (°C)	-22 to 158°F (-30 to 70°C)	-22 to 158°F (-30 to 70°C)	-22 to 158°F (-30 to 70°C)	-22 to 158°F (-30 to 70°C)
	Relative humidity	%	0-95%	0-95%	0-95%	0-95%
	Altitude	ft (m)	≤ 6562 (2000) full load 6562-9843 (2000-3000) derated	≤ 6562 (2000) full load 6562-9843 (2000-3000) derated	≤ 6562 (2000) full load 6562-9843 (2000-3000) derated	≤ 6562 (2000) full load 6562-9843 (2000-3000) derated
	Ingress Protection Rating	-	IP54	IP54	IP54	IP54
Other	3rd Party Rating	-	UL 1564 Compliant	UL 1564 Compliant	UL 1564 Compliant	UL 1564 Compliant
	Warranty Term	-	->	->	->	->

NOTES:

* Periodic full discharge and charge needed to balance cells and maintain battery warranty. See full warranty statement for complete details

** Short circuit, overcurrent, overvoltage, reverse connection, current backflow protection, isolation

*** Breaker typically 25% greater than input current, consult electrical professional for your situation

2 Year Warranty, Terms and Conditions Apply. See full warranty statement for complete details

OPTIONS INFORMATION

OPTIONS INFORMATION - NORTH AMERICA

PERFORMANCE	STD	OPT
154.5 Volt electrical system with GB250 Connection	X	
Standard (-10° C to 45° C) Environmental construction	X	
Drum Brakes	X	
Antistatic Strap	X	
154.5V302Ah (46.7kWh) Integrated Li-ion battery	X	
Charger (220V Three Phase Input / 100A Output)		X
Charger (480V Three Phase Input / 100A Output)	X	
Charger (600V Three Phase Input / 100A Output)		X
Charger (480V Three Phase Input / 150A Output)		X
Battery Disconnect	X	
Directional Lever	X	
MONOTROL® Directional Control Pedal		X
Standard Tread tires	X	
Dual Tread tires		X
Tires - Super Elastic	X	
Tires - Super Elastic - Non Marking		X
Tires - Pneumatic Radial		X
Steering Column Mounted Directional Control	X	
Steering Wheel with Spinner Knob	X	
Steer Column with Infinitely Adjustable Tilt	X	
On Demand Power Steering	X	
2 Stage Limited Free Lift Mast – Class III	X	
3 Stage Full Free Lift Mast – Class III		X
6° Forward / 12° Back Mast Tilt	X	
6° Forward / 6° Back Mast Tilt		X
6° Forward / 10° Back Mast Tilt (for cab)		X
3° Forward / 6° Back Mast Tilt		X
Tilt Cylinder Boots		X
Hook Type Standard Carriage - 54" Class 3/4	X	
Hook Type Standard Carriage - 63" Class 3/4		X
Hook Type Standard Carriage - 67" Class 3/4		X
Hook Type Standard Carriage - 71" Class 3/4		X
Hook Type Integral Sideshift Carriage - 54" Class 3/4		X
54" Cascade Hang-On Sideshift Carriage (Hook Type Forks)		X
49" Cascade Hang-On Sideshift Carriage with Fork Positioner (Hook Type Forks)		X
42" Long Hook Type (2" x 5.9") Standard Tapered Forks	X	

PERFORMANCE	STD	OPT
Without Load backrest		X
47" High Load Backrest Class 3	X	
51.5" High Load Backrest Class 4		X
Manual Lever Hydraulic Control	X	
Clamping function		X
2 Function (0 Auxiliary) Hydraulic Valve		X
3 Function (1 Auxiliary) Hydraulic Valve	X	
4 Function (2 Auxiliary) Hydraulic Valve		X
LED Work lights		X
LED Rear light package Brake/Tail/Backup		X
LED Rear light package Brake/Tail/Backup/Turn		X
Audible Reverse Alarm		X
Switch Activated Strobe Light		X
Dual Side View Mirrors		X
Rear reflector	X	
Blue LED Pedestrian Awareness Spotlights		X
Red LED Pedestrian Awareness Perimeter Lines		X
Parking Alarm	X	
94" Overhead Guard	X	
Non Suspension Vinyl Seat with hip restraint		X
Full Suspension Vinyl Seat with hip restraint	X	
Full Suspension Vinyl Seat with hip re- straint or flip up armrest		
Standard Seat Belt with Interlock	X	
Cabin Options (Partial, Steel Doors)		X
Rear Drive Handle with Horn Button		X
Toolbox		X
LCD Dash Display	X	
Heater/Demister		X
Single USB Port		
Traction speed limiters		X
Key Switch Start	X	
Battery disconnect	X	
Telemetry Prepared	X	
Speed Reduction in Corners		X
Foot Direction Control		X
Hyster Tracker Wireless Monitoring	X	
Hyster Tracker Wireless Access		X
Hyster Tracker Wireless Verification		X
Pedestrian Awareness Camera		X
Load Weight Indicator		X
Operator Presence System	X	
Camera System (Rear / front mounted) with LCD display		X
Speed reduction with elevated mast		X
Hyster yellow paint base truck	X	
12 Month / 2000 hour Limited Warranty (parts only)	X	

PERFORMANCE	STD	OPT
5 years / 3000 cycles Integrated Li-ion Battery Warranty	x	
2 years Li-ion Charger Warranty	x	



Hyster Company

P.O. Box 7367

Greenville, NC 27835-7367

U.S.A.

hyster.com

© 2026 Hyster-Yale Materials Handling, Inc., all rights reserved. HYSTER and [LOGO] are trademarks of Hyster-Yale Materials Handling, Inc. Trucks may be shown with optional equipment and/or features not available in all regions. Truck performance may be affected by the condition of the vehicle, how it is equipped and the application. Specifications are subject to change without notice. Consult your Hyster® Dealer if any of the information shown is critical to your application.

CERTIFICATION: Hyster lift trucks meet the design and construction requirements of B56.1-1969, per OSHA Section 1910.178(a)(2), and also comply with the B56.1 revision in effect at time of manufacture.