

R30XMF₃ SERIES

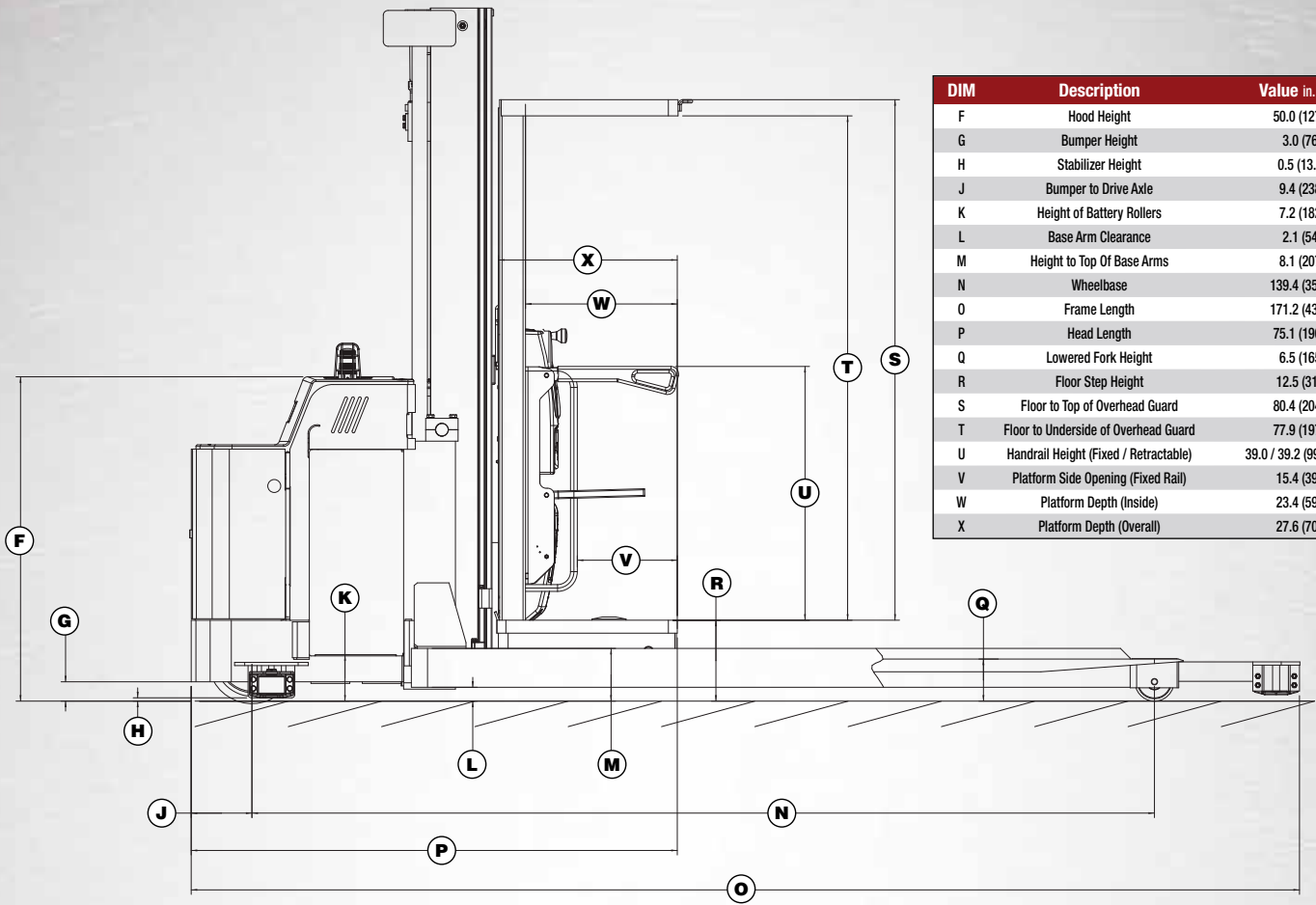

TECHNICAL GUIDE
Furniture Mover OrderPicker

R30XMF₃ DIMENSIONS



DIM	Description	Value in. (mm)
F	Hood Height	50.0 (1272)
G	Bumper Height	3.0 (76)
H	Stabilizer Height	0.5 (13.1)
J	Bumper to Drive Axle	9.4 (238)
K	Height of Battery Rollers	7.2 (182)
L	Base Arm Clearance	2.1 (54)
M	Height to Top Of Base Arms	8.1 (207)
N	Wheelbase	139.4 (3540)
O	Frame Length	171.2 (4349)
P	Head Length	75.1 (1907)
Q	Lowered Fork Height	6.5 (165)
R	Floor Step Height	12.5 (317)
S	Floor to Top of Overhead Guard	80.4 (2042)
T	Floor to Underside of Overhead Guard	77.9 (1978)
U	Handrail Height (Fixed / Retractable)	39.0 / 39.2 (990 / 995)
V	Platform Side Opening (Fixed Rail)	15.4 (392)
W	Platform Depth (Inside)	23.4 (595)
X	Platform Depth (Overall)	27.6 (702)

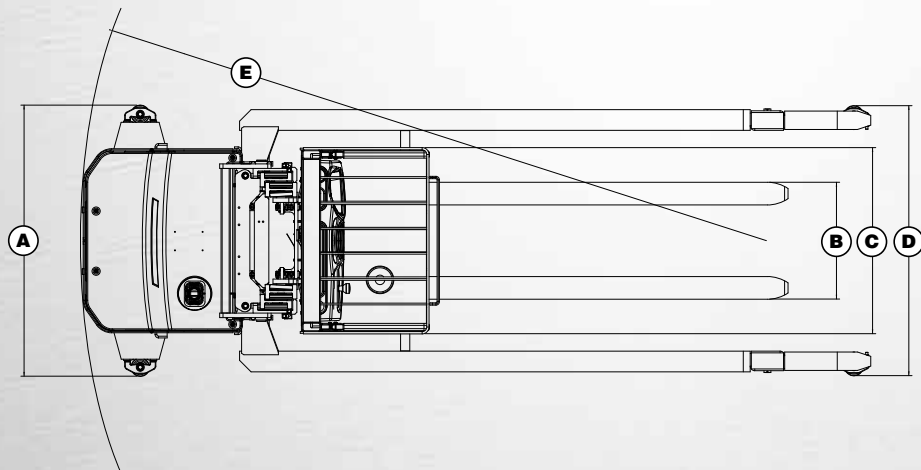

DIM	Description	Value in (mm)
A	Frame Width	52.5 (1334)
		54.5 (1384)
		56.8 (1443)
B	Fork Width	22.8 to 28.0 (580 to 711)
		58.5 (1486)
C	Platform Width	40.2 (1022)
D	Overall Width	52.5 (1334)
		54.5 (1384)
		56.8 (1443)
E	Turning Radius	58.5 (1486)
		149 (3793)

R30XMF₃ SPECIFICATIONS

GENERAL	1		Manufacturer	HYSTER	HYSTER
		2		Model Designation	R30XMF ₃
	3		Power / Voltage	Electric / 24 Volts	Electric / 36 Volts
	4		Operation Type	Stand-up	Stand-up
	5		Rated Capacity	lb. (kg)	1500 (680)
	6		Load Center	in. (mm)	48 (1219)
	7		Tire Type, front / rear	load / drive	Poly / Poly
	8		Wheels (X=driven)	front / rear	2 / 3 / (1X)
	9		Mast - 3-Stage (TOF)	in. (mm)	See Mast Chart
DIMENSIONS	10		Operator Clearance Height	in. (mm)	77.9 (1978)
	11		Forks, Width / Thickness	in. (mm)	5 / 2 (130 / 50)
	12		Fork Spread, Inside to Inside	Minimum / Maximum in. (mm)	13 / 18 (330 / 457)
	13		Fork Spread, Outside to Outside	Minimum / Maximum in. (mm)	23 / 28 (584 / 710)
	14		Top of Fork, Mast Lowered	in. (mm)	6.5 (165)
	15		Head Length, length to face of operator deck	3-Stage in. (mm)	75.1 (1907)
	16		Base Width	in. (mm)	See Chart
	17		Height, Standard 3 Stage Mast Lowered	in. (mm)	107 (2718)
	18		Operator Platform Size	Width / Depth in. (mm)	40 / 27.5 (1016 / 698)
	19		Turning Radius, minimum outside	in. (mm)	149.3 (3793)
	20		Stacking Aisle, Zero Clearance w / 48" W x 96" L pallet	in. (mm)	163.2 (4145)
21		Intersecting Aisle, equal aisles w / 48" W x 96" L pallet	in. (mm)	113.3 (2878)	
PERFORM.	22		Stability, Comply with ANSI?	YES	YES
	23		Travel Speed*	NL / RL mph (km/h)	6.5 / 6.5 (10.5 / 10.5)
	24		Lift Speed	NL / RL ft/min	See Performance Chart
	25		Lower Speed	NL / RL ft/min	See Performance Chart
WT.	26		Truck Weight	Without Battery NL lb. (kg)	7050 (3198)
	27		Axle Loading - Drive	Static with Max. Wt. Battery NL / RL lb. (kg)	6493 / 5476 (2945 / 2484)
WHEELS/TIRES	28		Axle Loading - Load Wheels	Static with Max. Wt. Battery NL / RL lb. (kg)	2557 / 6574 (1160 / 2982)
	29		Tire Size, Drive	in. (mm)	13.5 / 5.5 (343 / 140)
	30		Tire Size, Loadwheel	in. (mm)	6.0 / 3.0 (152 / 76)
	31		Wheelbase	in. (mm)	139.4 (3540)
	32		Ground Clearance	No load , lowest point in. (mm)	0.5 (13)
	33		Ground Clearance	No load , center wheelbase in. (mm)	2.1 (54.4)
ELECTRIC	34		Brakes, Method of Control	Service / Parking	Foot
	35		Brakes, Method of Operation	Service / Parking	Spring Applied / Electric Released
	36		Battery	Type	Lead Acid
	37			Volts	24
	38			Minimum Weight	lb. (kg)
	39		Traction Motor Control Method		AC Transistor
	40		Pump Motor Control Method		Contactor
	41		Number of Travel Speeds		Infinitely Variable

Right Angle Stack and Equal Intersecting Aisle dimensions provided with a 40" wide x 48" long pallet load, allowing zero clearance.
*Speeds are the same in either direction, with or without rated load. Steer angle <10 degrees.

CERTIFICATION: These Hyster® lift trucks meet design specifications of Part II ANSI B56.1-1969, as required by OSHA Section 1910.178(a)(2) and also comply with Part III ANSI B56.1-revision in effect at time of manufacture. Certification of compliance with the applicable ANSI standards appears on the lift truck. Performance specifications are for a truck equipped as described under Standard Equipment on this Technical Guide. Performance specifications are affected by the condition of the vehicle and how it is equipped, as well as by the nature, condition of the operating area, proper service and maintenance of the vehicle. If these specifications are critical, the proposed application should be discussed with your dealer.

Battery Specifications							
Number of Cells	Cell Size	Plates per Cell	Capacity 6 Hr Rate	Battery Dimensions			Weight
				"X" (Width)	"Y" (Length)	"Z" (Height)	
			amp hr (kwh)	in. (mm)	in. (mm)	in. (mm)	lb. (kg)
12	125	17	1000 (23.4)	38.1 (969)	13.5 (342)	30.6 (776)	1818 (825)
12	140	17	1120 (26.2)	38.1 (969)	13.5 (342)	30.6 (776)	1851 (840)
12	155	17	1240 (29.0)	38.1 (969)	13.5 (342)	30.6 (776)	1860 (844)
18	125	11	625 (21.9)	38.1 (967)	13.3 (339)	30.6 (776)	1800 (816)
18	140	11	700 (24.6)	38.1 (967)	13.3 (339)	30.6 (776)	1849 (839)
18	155	11	775 (27.2)	38.1 (967)	13.3 (339)	30.6 (776)	1859 (843)

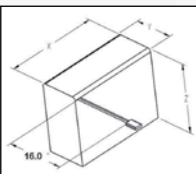

Battery Compartment Length is measured from front to rear. Battery Compartment Width is measured across truck. SB350 Amp "Red" Connector, Cable Position B, Cable Length 16" (405mm). Maximum Cable Gauge 1/0 AWG. Battery with lid will NOT fit in battery compartment. Battery Weight Range 1500 - 2000 lbs. Amp Hour Capacity Min / Max - 24 volt truck 960 / 1240. 36 volt truck 600 / 775.

Travel Speeds (24V & 36V)		
Fork Height in (mm)	Steer Angle <10° mph (kph)	Steer Angle >10° mph (kph)
0 (0)	6.5 (10.5)	6.5 (10.5)
24 (610)	6.5 (10.5)	3.0 (4.8)
60 (1524)	6.0 (9.7)	2.7 (4.4)
116 (2946)	4.7 (7.5)	2.3 (3.6)
150 (3810)	3.9 (6.2)	2.0 (3.2)
195 (4953)	2.8 (4.5)	1.6 (2.6)
250 (6350)	1.5 (2.4)	1.2 (1.9)
272 (6909)	1.0 (1.6)	1.0 (1.6)
>272 (6909)	No Travel*	No Travel*

Note: Speed limits are for trucks at operating temperature with fully charged battery. Speeds are the same in either direction, with or without rated load.

For lift heights between 24.0" (610 mm) and 272.0" (6909 mm), traction speed is reduced when steering angle exceeds 10°.

* Travel above 272.0" (6909 mm) fork height requires a High level traction option. Capacity reduction required.

Contact your local dealer for additional information.

STANDARD FEATURES AND OPTIONS

STANDARD EQUIPMENT

- 240" MFH / 107" OALH 3-Stage Anti-Rattle Mast
- 40.0" Wide X 27.5" Deep Operator Platform
- 78.0" x 2.00" x 5.0" Standard Taper Pin Type Forks
- 13.5" x 5.5" Vulkollan Polyurethane Drive Tire
- 6.0" x 3.0" Articulating Tandem - High Load Compound Load Wheel
- 39.0" L x 14.6" W x 31.5" H Battery Compartment
- 175 Amp Red, Position B - 16" Lead Length Battery Connector
- 24 Volt AC Electrical System
- Standard Application / Environmental Construction
- 42" Inside Dimension (Open End Clearance) 51.25" Outside Dimension (Base Width) Basearms
- UL Classification Type "E"
- Key Switch Start
- Return to Center Steering
- Ergonomically Advanced Multi-Function Control Handle with Rotational Adjustment and Single Speed Lift/Lower
- Electric Park Brake - Automatically Engaged / Foot Released
- Heavy Duty Pallet Clamp - Automatically Engaged / Foot Released
- AC Transistor Control
- AC Traction Motor
- Single Hydraulic Pump and Motor
- Controller Area Network (CANbus) Communications
- On Demand Electric Power Steering
- AC Steer Motor
- Auto Deceleration System (ADS) with Regenerative Braking
- Graphic LCD Multi-Function Smart Display with Back Lighting
 - Hour Meters; Truck, Traction and Hoist Pump
 - Bar Graphic Battery Discharge Indicator
 - Low Battery Lift Interrupt
 - Performance Mode Selection and Indication
 - LED Status Indicators with Symbols
 - 4 Operator Selectable, Programmable Performance Modes
 - User Passwords and Operator Logs with History
 - Steer Wheel Angle Graphic Indication
 - Truck Inspection Check List
 - Truck Speed Indication in MPH or KPH
- 8" x 2.5" Dual Polyurethane Caster Wheels
- 3.0" x 2.75" Polyurethane Guide Rollers
- Cantilever Style Overhead Guard
- Wire Mesh Screen Operator Guard
- Amber LED Strobe - Continuous Operation with Key-on
- HySense Continuous Height Sensing
- Slack Chain Indication
- Shock Dampening Operator's Compartment Floor Mat
- Battery Power Disconnect Button
- Operator Convenience Station with Storage Areas, Trash Bin, Beverage & Clipboard Holders
- Full Body Harness and Operator Tether
- Battery Compartment Corrosive Resistant Steel Rollers
- Retractable Platform Side Gates with Cushioning and Lift / Traction Cutout Interlock
- Electric Horn

- Static Discharge Strap
- Operating Manual and Labels - English
- 12 Month / Unlimited Hours Full Truck Warranty
- 3 Years/ 6,000 Hour Powertrain Warranty
- Lifetime Frame Warranty

OPTIONAL EQUIPMENT

- 36 Volt AC Electrical System
- Battery Stand
- Battery Puller
- Basearm Options
 - 44" Inside Dimension (Open End Clearance) 53.25" Outside Dimension (Base Width)
 - 46" Inside Dimension (Open End Clearance) 55.25" Outside Dimension (Base Width)
 - 48" Inside Dimension (Open End Clearance) 57.25" Outside Dimension (Base Width)
- Operator Platform
 - 27.5" Deep x 48" Wide
 - 27.5" Deep x 54" Wide
 - 27.5" Deep x 60" Wide
- Safety Glass Shield
- Fixed Hoop Side Rails
- 6" Vertical Adjustable Operator Console
- Retractable Operator Tether with Full Body Harness or Medium Body Belt
- Heavy Duty Automatic Pallet Clamp with opening range from 1/2" to 6"
- Keyless - Toggle switch
- Various Mast Options Available
- 84.0" x 2.00" x 5.0" Standard Taper Pin Type Forks
- Lift Limit with or without Push Button Override
- Lowering Limit With Push Button Override
- High Level Traction above 272" with Restricted Steer
- Polyurethane - Black (80 Durometer) Press-on Drive Tires
- Light Packages
 - Dome Light and 2 Speed Fan Package Mounted on Top of Overhead Guard
 - Dome Light, 2 Speed Fan and Halogen Glass Lens Spot Light Package
 - Dome Light, 2 Speed Fan and LED Plastic Lens Spot Light Package
 - 2 LED Plastic Lens Spot Lights Mounted Under Overhead Guard
- DC to DC Converter - 25 amps / 300 watts @ 12 volts
- Multi-Turn Steering
- Audible Alarms Self Adjusting 82-102 db(A)
 - Back-Up Alarm - Reverse Direction Activation
 - Motion Alarm - Forward and Reverse Direction Activation
 - Motion Alarm - Continuous Operation with Key-on
- 2 Speed Upper Body Fan - Console Mounted
- 30" Tether Boom Extension
- Basearm Cross Tie
- Parts Manual - Printed or CD

Mast Performance

	Lifting Speed		Lowering Speed	
	Empty	Rated Load †	Empty	Rated Load †
24V DC	67 ft/min (0.340 m/s)	45 ft/min (0.229 m/s)	80 ft/min (0.406 m/s)	80 ft/min (0.406 m/s)
36V DC	78 ft/min (0.396 m/s)	63 ft/min (0.320 m/s)	80 ft/min (0.406 m/s)	80 ft/min (0.406 m/s)

† Rated load figures are based on 1500 lb. load (680 kg) and a 48" load center.
 NOTE: Performance specifications are for truck with Standard Equipment. Performance specifications are affected by the condition of the vehicle and how it is equipped as well as the nature and condition of the operating area. If these specifications are critical, the proposed application should be discussed with your dealer.

Mast Dimensions

	Maximum Fork Height (TOF)	Overall Lowered Height	Overall Extended Height
	in. (mm)	in. (mm)	in. (mm)
	240" (6096)	107" (2718)	327" (8306)
	270" (6858)	119" (3023)	357" (9068)
3-Stage (6.9")	300" (7620)	131" (3325)	387" (9830)
	330" (8382)	143" (3632)	417" (10592)
	360" (9144)	155" (3937)	447" (11354)

Lift heights over 360" (9144 mm) maximum fork height may require reduced capacity depending upon OEC dimensions.



Hyster Company
 P.O. Box 7006
 Greenville, North Carolina
 27835-7006
 Part No. R30XMF3/TG
 10/2014 Litho in U.S.A.

Visit us online at www.hyster.com or call us at 1-800-HYSTER-1.

Hyster and  are registered trademarks of Hyster Company. Hyster products are subject to change without notice.

The Hyster Company products included in this document may be covered by US Patent 6,684,148, and other patents pending. Truck on cover shown with optional equipment. ©2014 Hyster Company. All rights reserved.